

1-bit processing of composite BOC (CBOC) signals and extension to time-multiplexed BOC (TMBOC) signals

Olivier Julien, Christophe Macabiau, Jean-Luc Issler, Lionel Ries

► To cite this version:

Olivier Julien, Christophe Macabiau, Jean-Luc Issler, Lionel Ries. 1-bit processing of composite BOC (CBOC) signals and extension to time-multiplexed BOC (TMBOC) signals. ION NTM 2007, National Technical Meeting of The Institute of Navigation, Jan 2007, San Diego, United States. pp 227-239, 2007, <<http://www.ion.org/publications/abstract.cfm?articleID=7153>>. <hal-01021981>

HAL Id: hal-01021981

<https://hal-enac.archives-ouvertes.fr/hal-01021981>

Submitted on 27 Oct 2014

HAL is a multi-disciplinary open access archive for the deposit and dissemination of scientific research documents, whether they are published or not. The documents may come from teaching and research institutions in France or abroad, or from public or private research centers.

L'archive ouverte pluridisciplinaire **HAL**, est destinée au dépôt et à la diffusion de documents scientifiques de niveau recherche, publiés ou non, émanant des établissements d'enseignement et de recherche français ou étrangers, des laboratoires publics ou privés.

1-Bit Processing of Composite BOC (CBOC) Signals and Extension to Time-Multiplexed BOC (TMBOC) Signals

Olivier Julien, Christophe Macabiau
ENAC, Toulouse, France

Jean-Luc Issler, Lionel Ries
CNES, Toulouse, France

BIOGRAPHIES

Olivier Julien is an assistant professor at the signal processing laboratory of ENAC (Ecole Nationale de l'Aviation Civile), Toulouse, France. His research interests are GNSS receiver design, GNSS multipath and interference mitigation and GNSS interoperability. He received his B.Eng in 2001 in digital communications from ENAC and his PhD in 2005 from the Department of Geomatics Engineering of the University of Calgary, Canada.

Christophe Macabiau graduated as an electronics engineer in 1992 from the ENAC (Ecole Nationale de l'Aviation Civile) in Toulouse, France. Since 1994, he has been working on the application of satellite navigation techniques to civil aviation. He received his Ph.D. in 1997 and has been in charge of the signal processing lab of the ENAC since 2000.

Jean-Luc Issler is head of the Transmission Techniques and signal processing department of CNES, whose main tasks are signal processing, air interfaces and equipments in Radionavigation, Telecommunication, TT&C, High Data Rate TeleMetry, propagation and spectrum survey. He is involved in the development of several spaceborne receivers in Europe, as well as in studies on the European RadioNavigation projects, like GALILEO and the Pseudolite Network. With DRAST and DGA, he represents France in the GALILEO Signal Task Force of the European Commission. With Lionel Ries and Laurent Lestarquit, he received the astronautic prize 2004 of the French Aeronautical and Astronautical Association (AAAF) for his work on Galileo signal definition.

Lionel Ries is a navigation engineer in the Transmission Techniques and signal processing department, at CNES since June 2000. He is responsible of research activities on GNSS2 signal, including BOC modulations and GPS

IIF L5. He is involved in the GALILEO program, in which he supports ESA, EC and GJU, through the GALILEO Signal Task Force. He graduated in 1997 from the Ecole Polytechnique de Bruxelles, at Brussels Free University, Belgium, in 1997, and received a M.S. degree from the Ecole Nationale Supérieure de l'Aéronautique et de l'Espace in Toulouse, France, in 1998.

ABSTRACT

The US and EU agreed recently to share a common normalized Power Spectral Density (PSD) function for their civil signal on L1. This PSD, referred to as Multiplexed Binary Offset Carrier (MBOC), because of its frequency definition, can lead to different temporal implementations. Two modulations were proposed to implement the MBOC: the Composite BOC (CBOC) seems to be the leading candidate for Galileo L1 OS signal, and the Time-Multiplexed BOC (TMBOC) seems to be the main candidate to be used by the GPS L1C signal.

These two modulations use the BOC(1,1) and BOC(6,1) waveforms, but in different ways. The CBOC adds them linearly, creating a multi-level waveform, while the TMBOC multiplexes them. Thus, although very close, the two MBOC implementations would require different architectures that will make the receiver more complex if traditional tracking techniques are used, especially for GPS/Galileo combined receivers (need for a local generation of a multi-bit replica and a time-multiplexed replica).

The goal of this paper is to present two tracking techniques that significantly simplify the receiver architecture of future GPS/Galileo L1 receivers (one-bit local replica, no time-multiplexing, ...) while maintaining good performances in presence of thermal noise and multipath. This means that the tracking techniques are

easily adaptable to both CBOC and TMBOC signals. Taking advantage of the GPSIII L1C and Galileo E1 OS interoperability and compatibility, these methods are a first step towards the development of combined GPS/Galileo receivers. The first technique, based on the use of either a pure BOC(1,1) or a pure BOC(6,1) sub-carrier in the correlation process, allows a drastic simplification of the receiver architecture, but implies a degradation of the tracking noise compared to traditional CBOC or TMBOC tracking, although improving the multipath resistance. The second technique is more demanding in terms of correlators since it requires the use of both a pure BOC(1,1) and a pure BOC(6,1) sub-carrier for the correlation process. However it brings improved tracking performances compared to traditional CBOC and TMBOC tracking and a high flexibility to the receiver architecture. These two techniques, though, seem more suited for CBOC tracking since a slightly more complex architecture is needed for relevant TMBOC tracking.

INTRODUCTION

After long technical discussions between the US and the European working groups in charge of the definition of the future GPSIII and Galileo civil signals broadcast on the L1 frequency, an agreement has been reached by both parties to try to transmit signals with a common normalized Power Spectral Density (PSD) [Godet and Crews, 2006; Hilbrecht and Braibanti, 2006]. This PSD is defined for the whole civil signals (gathering data and pilot components) and has a theoretical expression, assuming no filtering, given by:

$$G(f) = \frac{10}{11} G_{BOC(1,1)}(f) + \frac{1}{11} G_{BOC(6,1)}(f) \quad (1)$$

where $G_{BOC(1,1)}$ and $G_{BOC(6,1)}$ are the BOC(1,1) and BOC(6,1) PSDs respectively, which expression can be found in Betz (2002) or Rebeyrol et al. (2005).

Since it is based on two Binary Offset Carrier (BOC) modulations, this common PSD is referred to as Multiplexed BOC (MBOC) PSD. One of the driving technical reasons for this optimized signal was to put some power at away from the carrier frequency in order to improve tracking performances in presence of thermal noise and multipath compared to the use of the previous civil signal baseline (a pure BOC(1,1) signal). Obviously, other constraints such as the ability to only track the BOC(1,1) component with minimum degradations for low-cost receivers, or the interference with other navigation signals within the L1 band were thoroughly taken into account for the design of the MBOC.

Since the definition of the optimized signal is given in the frequency domain, this leaves some space for different implementations in the time domain. Two main implementations of the MBOC emerged recently [Hein et al. 2006]:

- the Composite BOC (CBOC), that seems to be the current preferred option for Galileo E1 signal. It is obtained by a linear combination of the BOC(1,1) and BOC(6,1) components, and
- the Time-Multiplexed BOC (TMBOC), that uses a time-multiplexing of the two BOC components. This option is currently the baseline option for the GPS L1C signal [Betz et al., 2006].

Because these two MBOC implementations are based on the same PSD, there is an underlying interoperability between the CBOC and TMBOC modulations, and thus potentially between the Galileo and GPS L1 civil signal, that emerges. However, using the traditional tracking method with the CBOC and TMBOC signals, a combined GPS/Galileo L1 receiver will have to generate very different (although based on the same components) local replicas: one encoded on 2-bit (for the CBOC) and one time-multiplexed (for the TMBOC).

The need for a multi-level CBOC replica has been felt as a drawback for the emerging CBOC in the current GNSS receiver technology. Thus, different tracking techniques using a 1-bit replica have been introduced to mitigate this drawback. The goal of this paper is to present two of these methods, and to analyze their adaptability with TMBOC signals. Indeed, as already mentioned, the essence of a common MBOC baseline is the signals' interoperability and it is believed that if this could be followed by a common tracking plate-form it would be very beneficial to the development of combined receivers for any users.

The first part of this article presents the Galileo E1 OS and GPS L1C main candidates as well as their expected performances. Then, the first CBOC/TMBOC tracking techniques is introduced and investigated in order to compare its performance with respect to traditional tracking. A special attention on its simple architecture is also drawn. Finally, the second CBOC/TMBOC tracking technique, more complex, is studied. It is shown that it has a value-added component due to its flexibility and its excellent performances compared to traditional CBOC/TMBOC tracking.

PRESENTATION OF CBOC AND TMBOC SIGNALS AND THEIR MAIN TRACKING PERFORMANCES

To implement the CBOC and TMBOC modulations, several parameters have to be defined in order to choose in a relevant way the weight of the BOC(1,1) and BOC(6,1) components to meet the MBOC PSD:

- The respective power of the data and pilot channels

- The respective weight of the BOC(1,1) and BOC(6,1) components within the data and pilot channels.

These two parameters differ between GPS and Galileo and thus a separate study of the current main respective candidates is necessary.

The Current Main Candidate for Galileo E1

In its baseline definition, the Galileo E1 civil signal will have a power split equally between the data and the pilot channels. It is also likely that both the data and pilot component will carry an equal amount of BOC(6,1), although several options are still under investigations. As already mentioned, the CBOC, invented by the CNES and the University FAF Munich, uses a linear combination of a BOC(1,1) and a BOC(6,1) sub-carrier, and consequently, the Galileo CBOC signal can be written as [Avila-Rodriguez et al., 2006]:

$$s_{OS}(t) = \begin{bmatrix} c_D(t)d(t)(Px(t)+Qy(t)) \\ + c_P(t)(Px(t)-Qy(t)) \end{bmatrix} \quad (2)$$

where c_D and c_P are the data and pilot channels spreading code sequences,

d is the navigation message,

x and y are the BOC(1,1) and BOC(6,1) sub-carrier waveforms respectively, and

$P = \sqrt{1/11}$ and $Q = \sqrt{10/11}$ are the respective weights of the BOC(1,1) and BOC(6,1) waveforms.

In the following, and to remain general, p will refer to the amount of BOC(6,1) power within the whole civil

channel (data or pilot) power with $p = \frac{Q^2}{P^2 + Q^2}$.

It can be seen that there is a sign inversion of the BOC(6,1) sub-carrier between the data and pilot channels. This is necessary to cancel the BOC(1,1)/BOC(6,1) cross-terms appearing on each channel and thus meet the MBOC constraint (Avila-Rodriguez et al., 2006) for the whole civil signal. This implies that Galileo E1 OS tracking can be realized on two distinct signal: a CBOC(6,1,p,'+') on the data channel and/or a CBOC(6,1,p,'-') on the pilot channel where the '-' or '+' represent the sign of the BOC(6,1) component. It can then be foreseen that the corresponding tracking performances will be different.

The Galileo OS data and pilot autocorrelation functions are given in [Julien et al. 2006] as:

$$R_{CBOC(-)}(\tau) = P^2 R_x(\tau) + Q^2 R_y(\tau) - 2PQR_{x/y}(\tau) \quad (3)$$

$$R_{CBOC(+)}(\tau) = P^2 R_x(\tau) + Q^2 R_y(\tau) + 2PQR_{x/y}(\tau)$$

Where R_x and R_y are the autocorrelation functions of the BOC(1,1) and BOC(6,1) waveforms respectively, and

$R_{x/y}$ is the cross-correlation function between the BOC(6,1) and BOC(1,1) waveforms.

The Main Candidate for GPS L1C Signal

As already mentioned, it seems that the GPS L1C will implement a TmBOC modulation. Following Hein et al. (2006), the general expression of the TmBOC is given by:

$$TMBOC(6,1,p)(t) = \begin{cases} c(t)x(t) & \text{if } t \in S_1 \\ c(t)y(t) & \text{if } t \in S_2 \end{cases} \quad (4)$$

where S_1 is the union of the segments of time when a BOC(1,1) sub-carrier is used, while S_2 , the complement of S_1 in the time domain, is the union of the segments of time when a BOC(6,1) sub-carrier is used.

To respect the notations used for the CBOC, it should be mentioned that the length of the segment S_2 should be $p\%$ of the spreading code length. Note that a relevant choice of the segments S_1 and S_2 has been shown to potentially reduce by 1 dB the auto and cross-correlation main peak isolation [Avila-Rodriguez et al., 2006].

According to Betz et al. (2006), the GPS L1C signal will have 75% of its power on the pilot channel and 25% on the data channel. Moreover, only the pilot channel will carry the BOC(6,1) component. This means that the data signal will be a pure BOC(1,1) signal while the pilot signal will be a TmBOC(6,1,4/33).

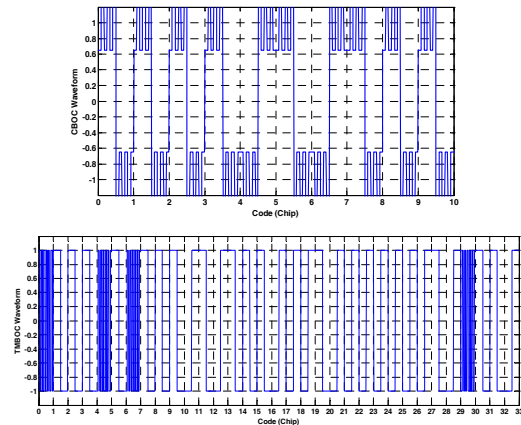

Figure 1 – Truncated CBOC(6,1,1/11,'-') (Top) and TMBOC(6,1,4/33) Waveforms

The proposed temporal realization of this TmBOC is to select 4 given chips every 33 chips of the spreading code length and modulate these 4 chips with a BOC(6,1) sub-carrier, while the remaining chips are modulated by a BOC(1,1) sub-carrier (Hein et al., 2006), as shown in

Figure 1. The resulting autocorrelation of a TMBOC pilot signal is generally given by:

$$R_{TMBOC(6,1,4/33)}(\tau) = P^2 R_x(\tau) + Q^2 R_y(\tau) \quad (5)$$

Where $P = \sqrt{\frac{29}{33}}$ and $Q = \sqrt{\frac{4}{33}}$ in the case of the candidate GPS L1C pilot signal.

Because only the GPS pilot channel might use a TMBOC modulation, and since this paper aims at looking at the GPS and Galileo interoperability at the tracking level, only the GPS and Galileo L1 civil signal pilot components will be studied herein. This choice is comforted by the fact that it is likely that most of the receiver will use only the pilot channels for tracking due to their more robust phase tracking capabilities and their aptitude for long coherent integration time.

It is very important to understand now that the GPS L1C and Galileo E1 OS pilot channels considered taken separately do not have the same PSD, as it can be extrapolated from their autocorrelation functions, and this might complicate the search for a common tracking architecture.

THEORETICAL MBOC TRACKING PERFORMANCES

It is well-known that the tracking performances of a signal under thermal noise and multipath are very dependent upon the narrowness of its autocorrelation main peak. The autocorrelation function of the Galileo OS and GPS L1C pilot channel candidates are shown in Figure 2. It can be seen that the CBOC(6,1,1/11,'-') and the TMBOC(6,1,4/33) have a very similar autocorrelation main peak similar and thus probably very similar tracking performances. However, they should both outperform the Galileo E1 OS data channel.

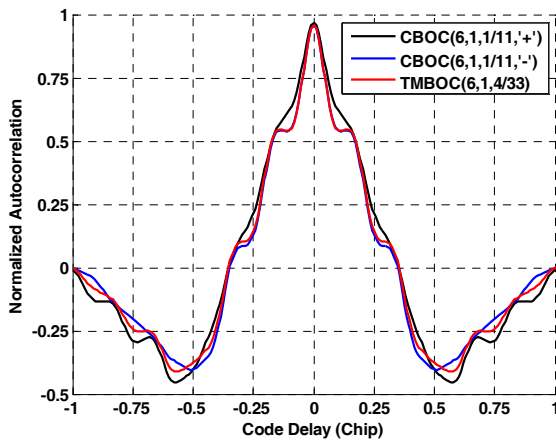

Figure 2 – CBOC(6,1,1/11,'+') , CBOC(6,1,1/11,'-') and TMBOC(6,1,4/33) Autocorrelation Functions for a 12 MHz One-Sided Filter

A theoretical study of the CBOC and TMBOC tracking performances in terms of tracking noise and multipath-induced error was done by Julien et al. (2006) assuming a Delay Lock Loop (DLL) using a Dot-Product (DP) discriminator. Only a brief reminder of the main elements and conclusions of that analysis will be given herein.

Assuming a DP discriminator and the use of a locally-generated replica identical to the unfiltered received waveform, the theoretical tracking error variance due to thermal noise is given by:

$$\sigma_{DP}^2 = \left(\frac{B_L(1-0.5B_L T_I) (\tilde{R}_{CBOC}(0) - \tilde{R}_{CBOC}(d))}{2N_0 \left(\frac{d\tilde{R}_{CBOC}(x)}{dx} \Big|_{x=d/2} \right)^2} \times \left(1 + \frac{\tilde{R}_{CBOC}(0)}{\frac{P_r T_I}{N_0} \tilde{R}_{CBOC}^2(0)} \right) \right) \quad (6)$$

where B_L is the DLL loop bandwidth,
 T_I is the coherent integration time,
 d is the early-late spacing,
 P_r is the incoming useful signal power (in the data or pilot channel),
 N_0 is the thermal noise PSD level,
 \tilde{R}_{CBOC} is the filtered correlator output noise correlation function, and
 \tilde{R}_{CBOC} is the filtered correlation function of the incoming signal.

Applied to the present case, this general formula can be used to compare the tracking error of the GPS L1C and Galileo E1 OS pilot current candidate signals with respect to the previous baseline, a pure BOC(1,1) signal. It can then be shown that the CBOC(6,1,1/11,'-') and the TMBOC(6,1,4/33) signals provide an excellent tracking improvement of 3.1 dBs.

In order to assess the resistance to multipath, a running average multipath error (RAME) has been selected as the main figure of merit. Its expression is given by Hein et al (2006):

$$A(\tau) = \frac{1}{\tau} \int_0^\tau |\max(E(x)) - \min(E(x))| dx \quad (7)$$

where E represents the well-known multipath envelope.

Figure 3 shows both the multipath envelope and the running average multipath error for the CBOC(6,1,1/11,'-') and TMBOC(6,1,4/33) signals compared to a pure BOC(1,1) signal for a 1/12 early-late chip spacing, a 12-MHz double-sided front-end filter and a signal-to-

multipath amplitude ratio (SMAR) of 0.5. It can be seen that they perform very well and provide a significant improvement against multipath compared to pure BOC(1,1) tracking. Only a slight difference between the CBOC(6,1,1/11,-) and TMBOC(6,1,4/33) multipath envelopes can be observed for the long delay multipath.

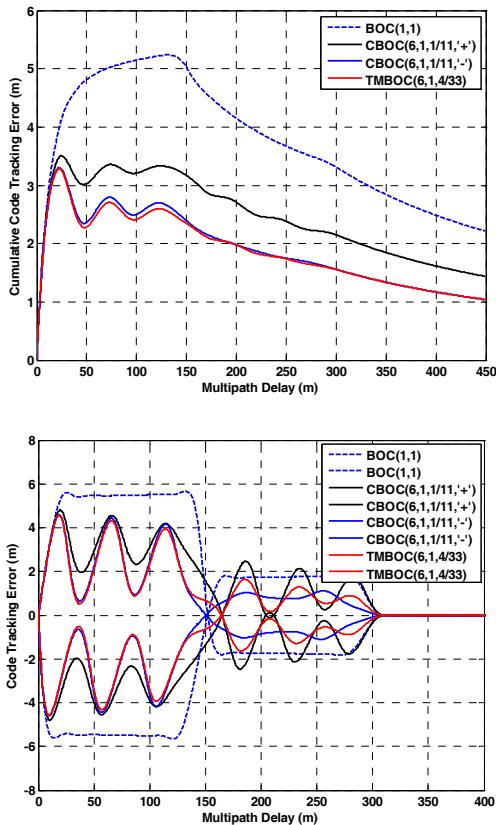

Figure 3 – CBOC(6,1,1/11,-) and TMBOC(6,1,4/33) Running Average Multipath Errors (Top) and Multipath Envelope (Bottom) Assuming a 1/12 Chip Early-Late Spacing, and a 12 MHz One-Sided Filter, and a 3 dB SMAR

Julien et al. (2006) also shown that the relative weights of the BOC(1,1) autocorrelation function, the BOC(6,1) autocorrelation function and the BOC(1,1)/BOC(6,1) cross-correlation function played an important role in the ability of the CBOC modulation to mitigate multipath. This result can be easily extended to TMBOC signals as well. This phenomenon can be observed on Figure 4 where the RAME is represented for different CBOC(6,1,p,-). It can be seen that excellent multipath performances can be achieved for values of p that are greater than the one selected for the MBOC. It is also interesting to note that among the interesting greater values of p , certain are better for short-delay multipath and others for long-delay multipath.

It can be shown that according to the CBOC or TMBOC autocorrelation formulation (with or without cross-

correlation term, sign of the cross-correlation) and according to the tracking parameters (early-late spacing, front-end filter bandwidth), the optimum can slightly vary. However, in any case, there is an optimal value of p in terms of running average multipath error that is usually greater than 0.15. This can be approximately translated into

$$\frac{P_{BOC(6,1)}}{P_{BOC(1,1)}} > 0.2 \quad (8)$$

Where $P_{BOC(6,1)}$ and $P_{BOC(1,1)}$ are the respective weights of R_y and R_x in the signal's autocorrelation function (see equations (3) and (6)).

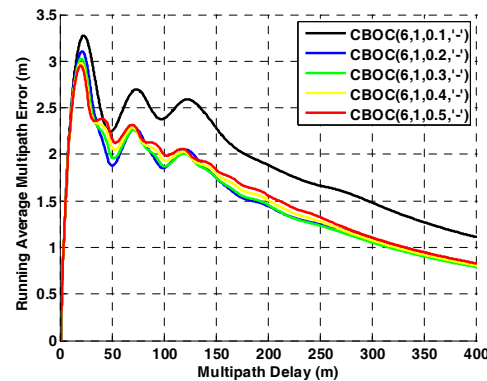

Figure 4 – Different CBOC(6,1,p,-) Running Average Multipath Error (Top) and Multipath Envelope (Bottom) Assuming a 1/12 Chip Early-Late Spacing, and a 12 MHz One-Sided Filter

To conclude on traditional MBOC tracking, it has been shown that the GPS L1C and Galileo E1 OS pilot signals present very good tracking performances against thermal noise and multipath compared to pure BOC(1,1) tracking. This shows how this optimized signal outperforms the previous Galileo and GPS baseline signal in terms of raw performances. However, the MBOC tracking performances shown are all obtained assuming the generation of a local replica that matches the unfiltered incoming signal. As already mentioned, this local replica is significantly different for the CBOC and the TMBOC:

- The TMBOC requires time-multiplexing and thus a logic device that chooses between the BOC(6,1) and the BOC(1,1) sub-carrier according to the generated code chip, and
- The CBOC requires generating a sub-carrier that is the sum (or difference) between two square sub-carriers. It is thus not binary and results in more complex receiver architectures with multi-bit generators and/or correlators.

In order to try to limit the complexity and changes of the receiver architecture compared to what is currently available, it is important to find solutions that should fulfill three objectives:

- Simplify the receiver architecture by using only 1-bit local replicas and a minimum of correlators,
- Be usable to receive both a CBOC(6,1,1/11) and a TMBOC(6,1,4/33) with a minimum of changes to put into perspective the interoperability of both signals based on the same PSD, and
- Limit the degradation compared to optimal reception of CBOC(6,1,1/11) and TMBOC(6,1,4/33) and have at least the same tracking performance than the optimal reception of a pure BOC(1,1) signal.

Indeed, because the two signals are based on the same two components, it would be of great interest to have tracking technique very similar that would lower the receiver complexity, while minimizing tracking losses due to non-optimal tracking.

The first method presented in the following section was already described by Julien et al. (2006) and was initially meant to allow CBOC tracking with a 1-bit local replica and a minimum number of correlators. It uses a TMBOC-like local replica to track the CBOC signal and thus is a good candidate to be also used for TMBOC tracking.

The second method uses the combination of two different correlations, one with a BOC(1,1) and one with a BOC(6,1) local replica. A thorough study of the combination process leads to interesting tracking performances but with the drawback of increasing the number of correlators.

METHOD 1: 1-BIT PROCESSING OF MBOC USING ONE CORRELATOR

The original idea for this method was to track a CBOC signal by generating a relevant 1-bit local replica that can take advantage of the good tracking capability brought by the BOC(6,1) component as well as the power brought by the BOC(1,1) [Julien et al., 2006]. In order to do so, a local replica similar to a TMBOC signal was investigated. To differentiate this local replica generated by the receiver from the TMBOC modulation received from the satellite, it will hereafter be referred to as TM61. It can be written as:

$$TM61(\alpha)(t) = \begin{cases} c(t)x(t) & \text{if } t \in S_3 \\ \pm c(t)y(t) & \text{if } t \in S_4 \end{cases} \quad (9)$$

where S_3 is the union of the segments of time when a BOC(1,1) sub-carrier is used, while S_4 , the complement of S_3 in the time domain, is the union of the segments of time when a BOC(6,1) sub-carrier is used. The parameter α represents the percentage of time when the BOC(6,1) sub-carrier is used. The choice upon the sign of the BOC(6,1) sub-carrier in the TM61 local replica depends upon the associated sign of the BOC(6,1) sub-carrier in the incoming CBOC signal. For instance, if it is a

CBOC('−') signal that is received, the BOC(6,1) sub-carrier in the TM61 replica will have a negative sign.

First, because it was designed for it, the performances of this TM61 method will be shown when tracking a CBOC(6,1,1/11,'−') signal. The CBOC/TM61(α) correlation function is given by:

$$R_{CBOC('−')/TM61(\alpha)}(\tau) = \begin{pmatrix} (1-\alpha)PR_x(\tau) + \alpha QR_y(\tau) \\ -(Q + \alpha(P-Q))R_{x/y}(\tau) \end{pmatrix} \quad (10)$$

Since a local replica different from the incoming signal is used, it is important to quantify the associated correlation losses. From equation (10), it can be shown that the TM61 resulting post-correlation SNR degradation, neglecting front-end filtering losses, is given by:

$$\text{deg}_{SNR} = (P + \alpha(Q - P))^2.$$

The resulting degradation is shown in Figure 5 and exhibits that the higher the proportion of BOC(6,1) in the TM61 local replica, the higher the post-correlation SNR degradation will be. Note that if a TM61(4/33), corresponding to the exact replica of the GPSIII L1C pilot signal, would be used, it would induce a degradation of only 1.2 dB.

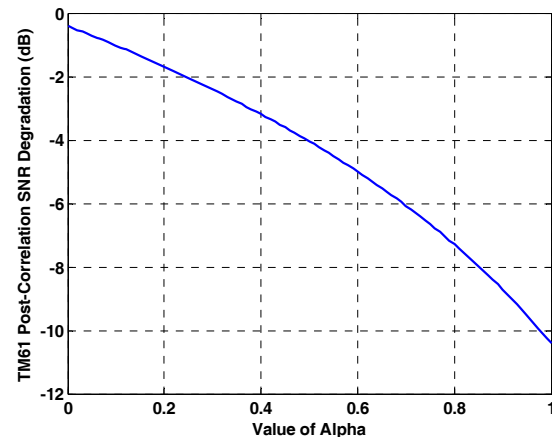

Figure 5 – TM61-Induced Post-Correlation SNR Degradation for CBOC(6,1,1/11) Signals

It is well known that a high post-correlation SNR degradation is detrimental for code tracking performances. Thus, if high values of α are desired, a modified code tracking architecture should be used. An interesting way to do so is to use a modified DP discriminator using a prompt correlation value with the lowest post-correlation SNR degradation possible [McGraw and Braasch, 1999]. For this reason, and referring to Figure 5, it was thus decided to use a DP discriminator with a prompt correlation value obtained using a local TM61(0) replica, or in other words a pure BOC(1,1). This allows to have, for a CBOC(6,1,1/11) signal, a post-correlation SNR degradation of only 0.4 dB

for the prompt correlator. Note that it is interesting to have a prompt replica that gathers as much power as possible for many other reasons such as:

- carrier-phase tracking (that uses only the prompt correlator output and thus will not be too degraded), or
- data demodulation (if method used on the data channel).

In this case, the modified TM61 DP discriminator can be written as:

$$D_{DP} = \left(\begin{array}{l} (I_E^{TM61(\alpha)} - I_L^{TM61(\alpha)}) I_P^{BOC(1,1)} \\ + (Q_E^{TM61(\alpha)} - Q_L^{TM61(\alpha)}) Q_P^{BOC(1,1)} \end{array} \right) \quad (11)$$

Using that approach and assuming that all the correlation functions are symmetric, the theoretical code tracking noise variance can be written equal to [Julien et al., 2006]:

$$\sigma_{DP, TM61(\alpha)}^2 = \left(\begin{array}{l} B_L(1 - 0.5B_L T_I) (\tilde{R}_{TM61(\alpha)}(0) - \tilde{R}_{TM61(\alpha)}(d))^2 \\ \times \left[\frac{P}{2N_0} \left(\frac{d\tilde{R}_{CBOC/TM61(\alpha)}(x)}{dx} \Big|_{x=\frac{d}{2}} \right)^2 \right. \\ \left. + \frac{\tilde{R}_{BOC(1,1)}(0)}{1 + \frac{P_r T_I}{N_0} \tilde{R}_{CBOC/BOC(1,1)}^2(0)} \right] \end{array} \right) \quad (12)$$

where $R_{TM61(\alpha)}$ is the TM61 autocorrelation function that corresponds to the TM61 local replica used for the early and late correlators.

From this expression, it can be observed that as expected:

- The squaring losses only depend upon the local prompt replica (the BOC(1,1)), and
- The asymptotical variance (when no squaring losses are present) depends upon the early and late TM61(α) local replicas only.

The resulting degradation for different values of α is given in Table 1. It seems that for certain values of α the tracking performances associated with the CBOC(6,1,1/11, '2-') signal outperforms pure BOC(1,1) tracking, which is very important to make this alternative CBOC tracking method worth using. Although the degradation compared to traditional CBOC(6,1,1/11, '2-') tracking is significant, this TM61 method would be of main interest if:

- the other sources of error, such as multipath, can be significantly improved compared to pure BOC(1,1) tracking, or even compared to traditional CBOC(6,1,1/11, '2-') tracking, and
- the receiver complexity can be significantly reduced compared to traditional CBOC tracking.

It is interesting to see that the interesting values for α are close to 0 and 1. This means that the lowest tracking noise are obtained either when a pure BOC(1,1) or a pure

BOC(6,1) are locally generated for the early and late correlators. This implies a significant simplification of the receiver architecture since in this case only pure sub-carriers have to be generated instead of time-multiplexed ones. It is also interesting to see that if the receiver uses the GPS TMBOC(6,1,4/33) signal as the local early and late TM61 waveforms, non-optimal tracking is achieved.

Table 1 – Theoretical TM61(α) Tracking Error Degradation wrt BOC(1,1) in Terms of Equivalent C/N₀ (dB) for a 12 MHz Front-End Filter and a 1/12 Chip Spacing

Value of α for Early and Late TM61(α) Local Replicas	TM61(α) Tracking Degradation with CBOC(6,1,1/11, '2-') wrt optimal BOC(1,1) and CBOC(6,1,1/11, '2-') Tracking in Terms of Equivalent C/N ₀ (dB)
0	-0.5 / 2.6
4/33	0.2 / 3.3
0.2	0.4 / 3.5
0.4	0.3 / 3.4
0.6	0.1 / 3.2
0.8	-0.2 / 2.9
1	-0.6 / 2.5

Concerning multipath, it has been seen earlier that the two CBOC/TM61(α) cross-correlation functions are a linear combination of the BOC(1,1) autocorrelation function, the BOC(6,1) autocorrelation function, and the BOC(1,1)/BOC(6,1) cross-correlation function. However, this time, the ratio between these three components is dependent upon the parameter α of the locally generated replica and could thus be controlled by the receiver setting. In the first section, it has been seen that certain values of this ratio implied better multipath resistance compared to the traditional CBOC(6,1,1/11, '2-') tracking. This can also be used to find an interesting value for α . The TM61 resulting running average multipath error is shown on Figure 6. It can be seen that the optimal local replica against single-multipath is a TM61(0.5). However, the use of a TM61(1), or a pure BOC(6,1), local replica for the early and late correlators is close to the optimum and outperforms a traditional pure BOC(1,1) tracking, and even a CBOC(6,1,1/11, '2-') tracking, especially for very short-delay and long-delay multipath.

As a conclusion it has been shown that the TM61 tracking method is efficient to track the Galileo E1 pilot component. Not only it reduces significantly the receiver architecture by using only pure local BOC sub-carriers, but when compared with a pure BOC(1,1) tracking, it improves code tracking by 0.6 dBs in terms of equivalent C/N₀. More important is the dramatic increase in terms of multipath mitigation since this figure of merit is improved compared to traditional CBOC(6,1,1/11, '2-') tracking. Note however, that compared to pure CBOC(6,1,1/11, '2-'), the tracking noise is increased by approximately 2.5 dBs, the drawback of a significant simplification of the receiver architecture.

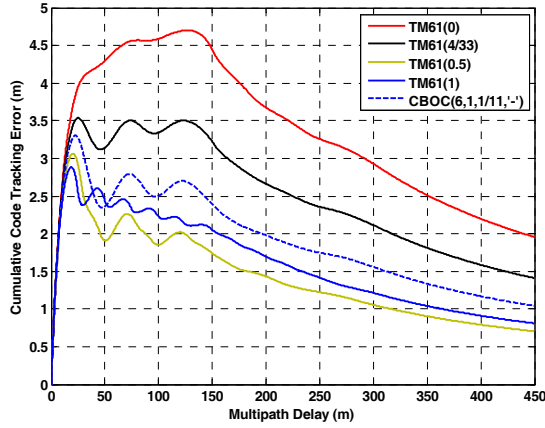

Figure 6 – Running Average Multipath Error using TM61 Tracking Technique for a CBOC(6,1,1/11,2-4) for an Early-Late Spacing of 1/12 Chips and a 12 MHz Double-Sided Front-End Filter

Extension to TMBOC Tracking

The ideal use of the TM61 tracking method for combined GPS/Galileo receivers would be the use of the GPS TMBOC(6,1,4/33) as the TM61 replica. However, it has been seen that if a TMBOC(6,1,4/33) was used to track the CBOC(6,1,1/11,2-4), the resulting performances would be too degraded to be considered really as a solution.

Because the TM61 method tries to take advantage of the BOC(1,1)/BOC(6,1) structure of the MBOC, this method should be however transposable to the TMBOC modulation. It has been seen that for the CBOC(6,1,1/11,2-4), it was interesting to have a pure BOC(1,1) replica for the prompt correlator and a pure BOC(6,1) replica for the early and late correlators. It is then interesting to test that configuration with the reception of a TMBOC(6,1,4/33).

It is well-known that because the TMBOC is time-multiplexed, it is more difficult, through a typical correlation process, to gather the power attached to one of the BOC components using the pure associated sub-carrier. Indeed, as an example, there are 4/33 chips that do not contain any BOC(1,1) when using a pure BOC(1,1) local replica. The post-correlation degradation is then:

$$\text{deg}_{SNR, TMBOC/BOC(1,1)}^{Blank} = P^4 \quad (13)$$

$$\text{deg}_{SNR, TMBOC/BOC(6,1)}^{Blank} = Q^4$$

And since $P, Q < 1$, this implies a degradation significantly twice higher (in dB) than for a CBOC signal. It is then not very interesting to use the TM61 method as the degradation in terms of post-correlation SNR would be too strong.

A method was proposed to solve this post-correlation SNR problem for BOC(1,1) receivers. It consisted in

blanking, during the correlation process, the part of the TMBOC signal with BOC(6,1) in order to reduce the noise component, while the gathered useful power is still the same. Transposing that to our case, the post-correlation SNR becomes:

$$\text{deg}_{SNR, TMBOC/BOC(1,1)}^{Blank} = P^2 \quad (14)$$

$$\text{deg}_{SNR, TMBOC/BOC(6,1)}^{Blank} = Q^2$$

Thus, the same degradation has for the equivalent CBOC signal is reached. It has however to be emphasized that this blanking method results in a partial correlation with respect to the spreading code. This means a potential degradation of the cross-correlation peak isolation, especially for the BOC(6,1) component. However, this TM61 technique being only for tracking and not for acquisition, and assuming that it is used with comfortable C/N_0 it is still interesting to go further into the investigation.

Using the same tracking error variance formula as for the CBOC (see equation (12)), it follows that the degradation obtained from the TM61 method with a TMBOC(6,1,4/33) signal in terms of C/N_0 compared to traditional TMBOC(6,1,4/33) tracking is of 2.3 dB, but it brings an improvement of 0.8 dBs compared to pure BOC(1,1) tracking. It is also understood that the multipath will be very similar to the BOC(6,1) multipath envelope thus better than the TMBOC(4/33) traditional tracking multipath envelope, as shown in Figure 7.

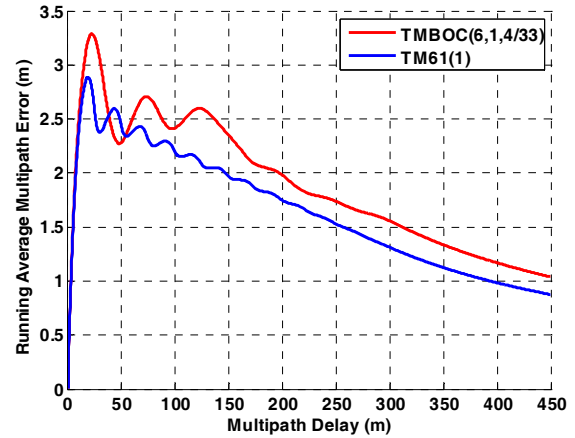

Figure 7 - Running Average Multipath Error using TM61 Tracking Technique for a TMBOC(6,1,4/33) for an Early-Late Spacing of 1/12 Chips and a 12 MHz Double-Sided Front-End Filter

Conclusions on the Use of the TM61 Tracking Technique for a Combined GPS/Galileo Receiver

The TM61 has been shown to be interesting for both TMBOC and CBOC tracking. It seems like the best TM61 candidate uses a pure BOC(1,1) replica for the prompt correlator, and a pure BOC(6,1) replica for the early and late correlators. This means the need for only pure sub-

carriers without time-multiplexing or multi-bit encoding, thus significantly simplifying the GPS/Galileo L1 receiver architecture, as shown in Figure 8.

This method is very well suited for CBOC signals, inducing tracking performances (tracking noise + multipath) significantly better than pure BOC(1,1) tracking. When compared to traditional CBOC tracking, there is a significant tracking noise degradation of 2.5 dBs, but with improved multipath mitigation. The phase tracking noise is however left unchanged.

The same configuration of the TM61 tracking technique is however more difficult to adapt for the TMBOC signal due to its time-multiplexed structure. To be efficient, there is a need to use blanking during the correlation process, and thus an additional complexity that might not be worth compared to the local generation of a time-multiplexed signal. However, it seems easier to generate a 1-bit signal with zeros than a time-multiplexed one. If blanking is used, the good performances observed for the CBOC are transposed to TMBOC tracking.

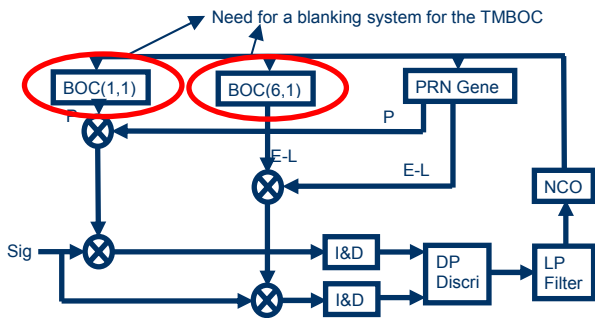

Figure 8 – TM61 Tracking Architecture for a Combined GPS/Galileo Receiver

METHOD 2: 1-BIT PROCESSING OF MBOC USING TWO CORRELATORS

The second tracking method considered in this paper is an extension of a method already mentioned by Avila-Rodriguez et al. (2006) and Julien et al. (2006). It considers that it is possible to use, for each correlation points used in the discriminator, two separate correlators: one using a pure BOC(1,1) local replica and one using a pure BOC(6,1) local replica. A linear combination of these two correlators' output using coefficients ρ and $-\beta$ can then to be formed in order to result in a relevant correlation function that will be used for tracking. Since this combination is made coherently, the 'correlation+combination' process is mathematically equivalent to the correlation between the incoming signal and a local waveform obtained through:

$$s_{Loc} = c_P(t)(\rho x(t) - \beta y(t)) \quad (15)$$

It can then be seen that this method is equivalent to the local generation of a CBOC(6,1, ρ' , β') waveform, where ρ and β define the linear combination and

$$\rho' = \frac{\beta^2}{\rho^2 + \beta^2} .$$

Two examples are shown in Figure 10

The resulting correlation functions of this waveform with the incoming CBOC(‘-’) and TMBOC waveforms are given by:

$$R_{CombCBOC(-)}(\tau) = \begin{pmatrix} \rho P R_x(\tau) + \beta Q R_y(\tau) \\ -(\rho Q + \beta P) R_{x/y}(\tau) \end{pmatrix} \quad (16)$$

$$R_{CombTMBOC}(\tau) = \begin{pmatrix} \rho P^2 R_x(\tau) + \beta Q^2 R_y(\tau) \\ -(\rho Q^2 + \beta P^2) R_{x/y}(\tau) \end{pmatrix}$$

Using the same analysis as for the TM61 method, the post-correlation SNR degradation with an infinite front-end filter for the CBOC and TMBOC signals can be obtained thanks to:

$$\text{deg}_{SNR,CBOC} = \frac{(\rho P + \beta Q)^2}{\rho^2 + \beta^2} \quad (17)$$

$$\text{deg}_{SNR,TMBOC} = \frac{(\rho P^2 + \beta Q^2)^2}{\rho^2 + \beta^2}$$

These degradations are shown in Figure 9. It can be seen that for the CBOC signal, the minimum post-correlation SNR degradation is obtained with $\frac{\rho}{\beta} = \frac{P}{Q} \approx 0.31$, which

was expected since it mathematically corresponds to the traditional tracking of a CBOC. Note that this choice for the parameters ρ and β corresponds to the 1-bit/2-correlator processing mentioned in Avila-Rodriguez et al. (2006).

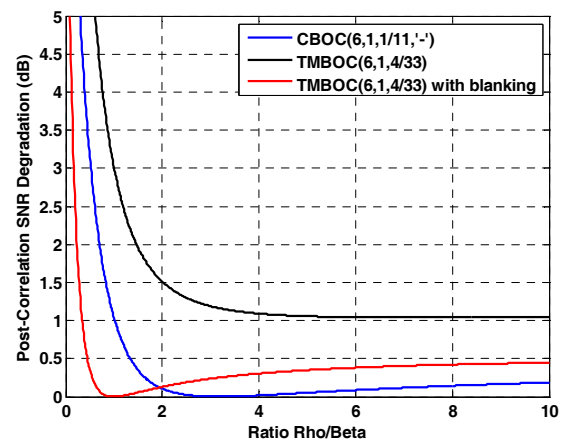

Figure 9 – CBOC and TMBOC Degradation for the 2 Correlation Method

It can also be seen that for the TMBOC, the degradation is significantly higher due to the time-multiplexed structure of the signal. Thus, as in the previous studied method, it is necessary to use blanking during the correlation process. Consequently, the locally generated BOC(1,1) replica has to be zeroed where the TMBOC(6,1,4/33) chips are modulated by a BOC(6,1) sub-carrier. Conversely, the locally generated BOC(6,1) replica has to be zeroed where the TMBOC(6,1,4/33) chips are modulated by a BOC(1,1) sub-carrier. It is then interesting to understand that the combination process makes the locally generated waveform a TMBOC(6,1,4/33) with a weight of ρ when a BOC(1,1) sub-carrier modulates the spreading chips and a weight of β when a BOC(6,1) sub-carrier modulates the spreading chips, as shown in Figure 10.

The resulting post-correlation SNR degradation changes to:

$$\text{deg}_{SNR, TMBOC}^{Blank} = \frac{(\rho P^2 + \beta Q^2)^2}{\rho^2 P^2 + \beta^2 Q^2} \quad (18)$$

and is shown in Figure 9.

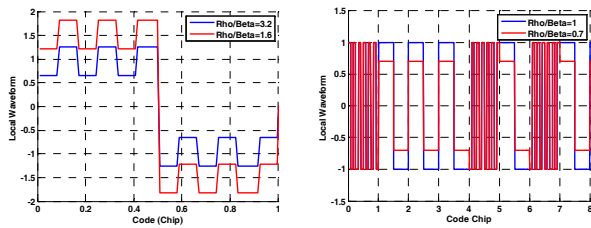

Figure 10 – Equivalent CBOC and TMBOC Local Replicas for the 1-Bit/2-Correlation Tracking Method

In this case, the optimal tracking is obtained for $\rho = \beta$. This is normal since in this case, the local replica can be visualized as the TMBOC(6,1,4/33) waveform.

Thus, we have seen that it is possible using this 1-bit/2-correlator method to reproduce the incoming waveforms for the CBOC and TMBOC cases, and thus to reach the same tracking performances in thermal noise as traditional tracking. However, this tracking method has the advantage to use soft values for the combination process. Thus, it is possible to easily modify these parameters in order to fulfil other tracking objectives such as interference or multipath mitigation. Indeed, the decoupling of the BOC(1,1) and BOC(6,1) correlations allows to recombine them by software and thus give a highly reconfigurable tracking method. Indeed, depending upon the objective to fulfill, it is significantly easier to change the values of ρ and β in software compared to the actual generation of a different waveform. Three interesting examples can be mentioned:

- If high sensitivity is needed, it is very interesting to use the values of ρ and β that minimize the post-correlation SNR degradation that were calculated before,

- In presence of a narrow-band interference around 6 MHz (from the carrier frequency), it would be interesting to switch to a tracking mode that would use only the BOC(1,1) component. Then, it is easy to take $\rho = 1$ and $\beta = 0$ (although in the case of CBOC, there is a BOC(6,1)/BOC(1,1) component, it is believed that it is less problematic), and
- In presence of strong multipath, it has been seen in the previous sections that there might be an optimal setting of ρ and β that minimizes multipath susceptibility.

Thus, the ability to change the parameters ρ and β easily during a tracking phase is of main interest.

As mentioned earlier, the code tracking depends greatly on the asymptotical behaviour of the code tracking variance expression given in the TM61 section. The degradation of this new 1-bit/2-correlators method compared to optimal CBOC tracking can then be calculated for an infinite bandwidth front-end filter through:

$$\text{deg}_{Track, CBOC('')} = \left(\frac{3\rho^2 + 23\beta^2 + 2\rho\beta}{(\rho(3P+Q) + \beta(23Q+P))^2} \times (3P^2 + 23Q^2 + 2PQ) \right) \quad (19)$$

The code tracking degradations for a CBOC(6,1,1/11, '-') and a TMBOC(6,1,4/33) are shown in Figure 11. This figure gives an idea of the code tracking degradation that would occur if a local waveform different from the incoming one is formed and used by the 1-bit/2-correlators method.

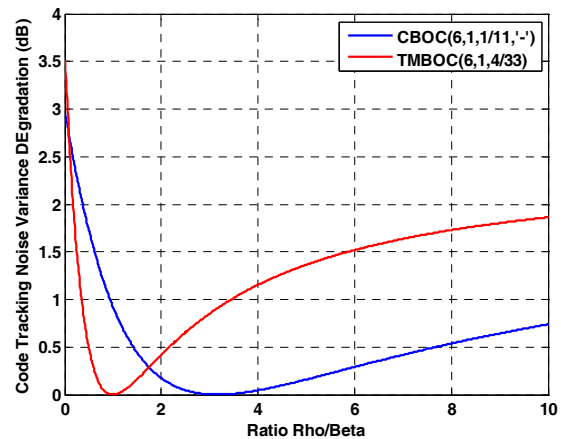

Figure 11 – CBOC(6,1,1/11, '-') and TMBOC(6,1,4/33) Code Tracking Degradation using the 1-Bit/2-Correlators Compared to Traditional CBOC(6,1,1/11, '-') and TMBOC(6,1,4/33) Code Tracking Noise

Taking a closer look at the multipath resistance of this tracking method, it has been shown earlier that the

multipath mitigation capability was dependent upon the ratio between the BOC(1,1) autocorrelation function and the BOC(6,1) autocorrelation function in the resulting correlation function between the incoming signal and the local replica. It has also been seen that it is good when this ratio is above 0.18 (see equation (8)) when a 12 MHz single-sided front-end filter bandwidth and a 1/12 chips early-late are chosen. So this means that in this situation:

- for the CBOC(6,1,1/11,'-') the ratio ρ/β should be lower than 1.6 approximately, and
- for the TMSBOC(6,1,4/33) the ratio ρ/β should be lower than 0.7 approximately.

The example of the CBOC(6,1,1/11,'-') has been taken as an example in Figure 12 to confirm this result. It can be seen that interesting values of ρ/β can lead to a significant improvement in terms of multipath mitigation compared to traditional tracking. Yet, as mentioned earlier, the choice of an optimum ρ/β against multipath is very dependent upon the tracking settings such as the front-end filter or the early-late spacing. It is however believed that an optimal ratio, different from the one associated with the CBOC(6,1,1/11,'-') and TMSBOC(6,1,4/33) traditional tracking can be found.

The interesting range of values given for the ρ/β ratio does not fit with an optimal tracking within thermal noise. It is then important to assess the degradation of this range of values in terms of code tracking noise. Figure 11 shows the code tracking degradation induced by different values of the ratio ρ/β for CBOC(6,1,1/11,'-') and TMSBOC(6,1,4/33,'-') tracking. It can be seen that by taking a value that is at the upper limit of the figures given above, the degradation is very limited. For instance a value of $\rho/\beta=1.6$ for CBOC(6,1,1/11,'-') means a tracking degradation of approximately 0.4 dBs, which is negligible, especially given the fact that the multipath rejection is improved. Moreover, in this case, the post-correlation SNR is only of 0.3 dBs, thus without consequence on code tracking either.

This result is very interesting because it means that the overall (noise+multipath) optimal reception of a CBOC(6,1,p) could be a different CBOC(6,1,p') with a p' that has to be computed according to the receiver settings. In the same way, the overall optimal reception of a TMSBOC(6,1,p) could be a different TMSBOC(6,1,p') with different levels between the BOC(1,1) and the BOC(6,1) part.

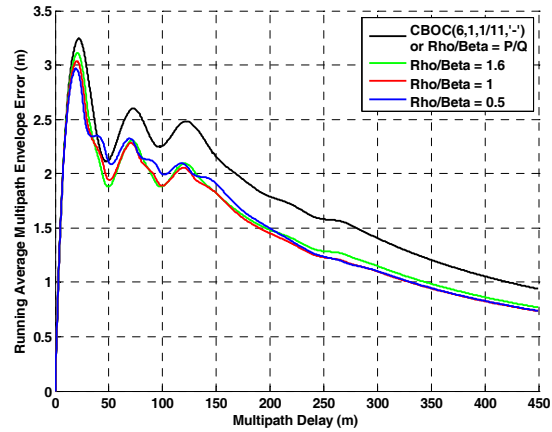

Figure 12 - Running Average Multipath Error for a CBOC(6,1,1/11,'-') and Different Values of ρ/β for an Early-Late Spacing of 1/12 Chips and a 12 MHz Double-Sided Front-End Filter

Since this method was not referenced anywhere, it is crucial to confirm by simulations the theoretical results, especially concerning code tracking noise. A series of tests were thus realized. To do so, a modular signal generator was used in order to simulate the CBOC(6,1,1/11,'-') and TMSBOC(6,1,4/33) signals. A single-sided front-end bandwidth of 10 MHz was simulated and a 20-second signal was generated in order to have relevant statistics.

The software receiver used a 10-Hz PLL aiding a 1-Hz DLL. The early-late spacing was set to 0.1 chip. A 4092-chip long spreading was used at a 1.023 MHz rate to simulate Galileo E1 civil signals. The coherent integration time was set to 4-ms.

The CBOC(6,1,1/11,'-') results are shown in Table 2. It can be seen that they fit accurately with the theoretical results. The TMSBOC(6,1,4/33) results are shown in Table 3. It can be seen that they fit accurately with the theoretical results.

As it was mentioned earlier, the 1-bit/2-correlators tracking technique was investigated to enable an adaptable tracking for CBOC and TMSBOC signals. It has been seen that different setting of the weighting parameters ρ and β could be used to meet different tracking objectives such as high multipath mitigation, high sensibility or side-band interference. The switching between these different tracking mode can be done only in software, thus being very simple to adapt for the receiver.

During the 1-bit/2-correlators tracking performance investigation, it has been seen that certain sets of values

for ρ and β result in an improved multipath mitigation with marginal code tracking degradation in thermal noise. This also shows that tracking a CBOC signal with a different CBOC local replica might be interesting for certain users.

Table 2 – CBOC(6,1,1/11,‘-‘) Simulation Results Compared to Traditional CBOC(6,1,1/11,‘-‘) Tracking

C/N ₀	Theoretical		30 dB-Hz		35 dB-Hz		40 dB-Hz		45 dB-Hz	
	ρ/β									
ρ/β	1.6	1	1.6	1	1.6	1	1.6	1	1.6	1
Post-Corr. SNR Deg. (dB)	0.3	1	0.4	1.3	0.4	1.2	0.2	0.9	0.3	0.9
Code Track. Err. Deg. (dB)	-	0.1	0.6	1.7	0	0.5	-	0.1	0.1	0.4
Phase Track. Err. Deg. (dB)	0.3	1	0.4	1.3	0.5	1.5	0.4	1.2	0.5	1.5

Table 3 – TmBOC(6,1,4/33) Simulation Results Compared to Traditional TmBOC(6,1,4/33) Tracking

C/N ₀	Theoretical		30 dB-Hz		35 dB-Hz		40 dB-Hz		45 dB-Hz	
	ρ/β									
ρ/β	0.7	0.5	0.7	0.5	0.7	0.5	0.7	0.5	0.7	0.5
Post-Corr. SNR Deg. (dB)	0.1	0.3	0.1	0.5	0.2	0.5	0.1	0.5	0.1	0.4
Code Track. Err. Deg. (dB)	-0.2	-	-	-	0.1	0.5	0.1	0.3	-	0.1
Phase Track. Err. Deg. (dB)	0.1	0.3	0.2	0.6	0.2	0.6	0.1	0.4	0.1	0.4

When adapting this method to TmBOC tracking, it has been seen that as in the TM61 case, a blanking operation during the 2 correlation processes is necessary to avoid strong SNR loss. This increases the TmBOC receiver architecture, but the flexibility of the parameters ρ and β is still believed to be an asset.

Finally, the 1-bit/2-correlators tracking technique, although more demanding in terms of correlators succeeds in providing good performances while keeping the CBOC/TmBOC receiver architecture very simple, as shown in Figure 13.

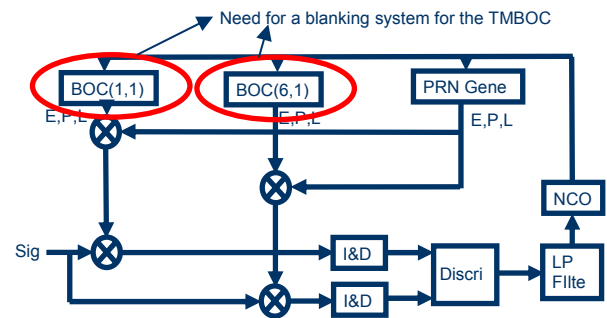

Figure 13 – 1-Bit/2-Correlator Tracking Architecture for a Combined GPS/Galileo Receiver

CONCLUSIONS

This paper showed that it was possible to track both the CBOC and TmBOC with a common simple receiver architecture and thus to facilitate the development of combined mass-market receivers. This conclusion was supported by two tracking techniques.

The first one is based on the local generation of a pure BOC(1,1) waveform for the prompt correlator, while the early and late correlators use a pure BOC(6,1) replica. These correlators’ outputs are then used in a modified DP discriminator. This means that the receiver only uses 1-bit local waveforms and no time-multiplexing to track CBOC and TmBOC signals, thus significantly simplifying the tracking loops. It was shown, however, that a blanking process is necessary for the TmBOC signal which might be a drawback for the use of this method for TmBOC tracking. It was also shown that this tracking technique brings an improvement in terms of multipath resistance compared to traditional CBOC/TmBOC tracking. However, it degrades code tracking noise by approximately 2.5 dBs, but improves it compared to pure BOC(1,1) tracking (which was the previous GPS/Galileo baseline for L1). Finally, phase tracking noise is left unchanged.

The second method correlates the incoming signal with a pure BOC(1,1) and a pure BOC(6,1) replica, thus doubling the required number of correlators, in order to form a new equivalent local waveform through a linear combination of the correlators’ outputs. Once again, a blanking process is necessary for the TmBOC signal which might be a drawback for the use of this method for TmBOC tracking. However, the choice of the equivalent waveform can be done in software and thus different configurations can be used according to the user need without extra complexity. It was seen that certain candidate combinations led to an improved resistance to multipath compared to traditional CBOC/TmBOC tracking while almost not degrading the code tracking noise. In particular, it was shown that a locally-generated CBOC different from the incoming one could be a

winning option. The same conclusion was drawn for TMBOC signals. Finally, it was foreseen that this tracking architecture could be interesting to fight narrow-band interferences located around 6 MHz away from the carrier frequency.

REFERENCES

- Avila-Rodriguez, J.-A., S. Wallner, G. Hein, E. Rebeyrol, O. Julien, C. Macabiau, L. Ries, A. Delatour, L. Lestarquit, and J.-L. Issler (2006), *CBOC – An Implementation of MBOC*, First CNES Workshop on Galileo Signals and Signal Processing, Toulouse, France, 12-13 Oct.
- Betz, J.W. (2002), *Binary Offset Carrier Modulations for Radionavigation*, Navigation: Journal of the Institute of Navigation, Vol. 48, Number 4, pp. 227-246.
- Betz, J., M. Blanco, C. Cahn, P. Dafesh, C. Hegarty, K. Hudnut, A. Jones, V. Kasemsri, R. Keegan, K. Kovach, S. Lenahan, H. Ma, and J. Rushanan (2006), *Description of the LIC Signal*, Proceedings of the ION GNSS Conference, Fort Worth, TX, USA, 26-29 Sept., to be published.
- Godet, J. and Col. M. Crews (2006), *WG A Recommendations on L1 OS / LIC Optimization*, March 22.
- Hein, G., J.-A. Avila-Rodriguez, S. Wallner, A R. Pratt, J Owen, J-L Issler, J W. Betz, C. J. Hegarty, Lt S. Lenahan, J. J. Rushanan, A. L. Kraay, and T. A. Stansell, *MBOC: The New Optimized Spreading Modulation Recommended for GALILEO L1 OS and GPS L1C*, Proceedings of IEEE/ION PLANS 2006, 24-27 April 2006, San Diego, CA, USA.
- Hilbrecht, H. and R. Braibanti (2006), *Joint Statement on Galileo and GPS Signal Optimization by the European Commission and the United States*, March 24.
- Julien, O., C. Macabiau, J.-L. Issler, and L. Ries (2006), *1-bit Processing of Composite BOC (CBOC) Signals*, First CNES Workshop on Galileo Signals and Signal Processing, Toulouse, France, 12-13 Oct.
- Rebeyrol, E., C. Macabiau, L. Lestarquit, L. Ries, J.-L. Issler, M.-L. Boucheret, and M. Bousquet (2005), *BOC Power Spectrum Densities*, Proceedings of the ION NTM 2005, 24-26 Jan. 2005, San Diego, CA, USA.