

# Investigation of Galileo E1 OS/SoL acquisition, tracking and data demodulation thresholds for civil aviation

Olivier Julien, Jean-Luc Issler, Lionel Ries

► **To cite this version:**

Olivier Julien, Jean-Luc Issler, Lionel Ries. Investigation of Galileo E1 OS/SoL acquisition, tracking and data demodulation thresholds for civil aviation. ION GNSS 2011, 24th International Technical Meeting of The Satellite Division of the Institute of Navigation, Sep 2011, Portland, United States. pp 1264-1276. hal-01022489

**HAL Id: hal-01022489**

**<https://hal-enac.archives-ouvertes.fr/hal-01022489>**

Submitted on 29 Sep 2014

**HAL** is a multi-disciplinary open access archive for the deposit and dissemination of scientific research documents, whether they are published or not. The documents may come from teaching and research institutions in France or abroad, or from public or private research centers.

L'archive ouverte pluridisciplinaire **HAL**, est destinée au dépôt et à la diffusion de documents scientifiques de niveau recherche, publiés ou non, émanant des établissements d'enseignement et de recherche français ou étrangers, des laboratoires publics ou privés.

# Investigation of Galileo E1 OS/SoL Acquisition, Tracking and Data Demodulation Thresholds for Civil Aviation

**Olivier Julien**

*Ecole Nationale de l'Aviation Civile (ENAC), Toulouse, France*

**Jean-Luc Issler, Lionel Ries**

*Centre National d'Etudes Spatiales (CNES), Toulouse, France*

## BIOGRAPHIES

**Olivier Julien** is an assistant professor at the signal processing laboratory of ENAC (Ecole Nationale de l'Aviation Civile), Toulouse, France. His research interests are GNSS receiver design, GNSS multipath and interference mitigation and GNSS interoperability. He received his engineering degree in 2001 in civil aviation with major in digital communications from ENAC and his PhD in 2005 from the Department of Geomatics Engineering of the University of Calgary, Canada.

**Jean-Luc Issler** is head of the Instrumentation Telemetry and Propagation department of the CNES Radiofrequency sub-directorate since august 2009. He is one of the CBOC inventors, and proposed the GALILEO E5 signal using the ALTBOC 8-PSK invention made by Laurent Lestarquit. He graduated first from the Ecole Supérieure d'Electronique de l'Ouest (ESEO). He received the Astronautic Prize of AAAF (french aeronautical and space association) in 2004, and the EADS Science and Engineering prize delivered in 2008 by the French Academy of Sciences for his work on GNSS frequencies and modulations, and spaceborne RF equipments.

**Lionel Ries** is head of the Signal and Radio-Navigation department of the CNES Radiofrequency sub-directorate since august 2009. He was a navigation engineer in the Transmission Techniques and Signal Processing department, at CNES since June 2000. He is one of the CBOC inventors. He graduated from the Ecole Polytechnique de Bruxelles, at Brussels Free University (Belgium) and received a M.S. degree from the Ecole Nationale Supérieure de l'Aéronautique et de l'Espace (SUPAERO) in Toulouse, France.

## ABSTRACT

The present article intends to propose acquisition, tracking and data demodulation thresholds for Galileo E1 OS civil aviation receivers. These thresholds are a mean to ensure that the performance of a simple Galileo E1 receiver is compatible with the civil aviation requirements related to the acquisition, tracking and data demodulation functions. The methodology to do so is taken from similar work realized by the Radio Technical Commission for Aeronautics (RTCA) for GPS, and adapted to the Galileo

case. The proposed threshold values are a post-correlation  $C/N_0$  threshold of 32 to 34 dB-Hz for acquisition and 29.5 dB-Hz for tracking and data demodulation.

## INTRODUCTION

The use of Galileo by the civil aviation community requires a thorough analysis of the signals' performance to ensure that a Galileo receiver on-board can fulfill a given set of requirements in worst-case operational conditions. These requirements can be found in civil aviation standardization documents such as, for instance, the Radio Technical Commission for Aeronautics (RTCA) DO-229D for the Minimum Operational Performance Standards (MOPS) for the GPS L1 C/A / WAAS airborne equipment. An equivalent document is currently being written by the EUROpean Organization for Civil Aviation Equipment (EUROCAE) for the use of Galileo by the civil aviation community. Certain requirements, such as the initial acquisition time, tracking accuracy, or the Word Error Rate (WER), are directly linked with the receiver's acquisition, tracking and data demodulation functions. The performance of these 3 functions are generally expressed as a function of the signal power to noise power spectral density ratio ( $C/N_0$ ). Consequently, as part of the assessment of the Galileo E1 Open Service (OS) signal for civil aviation, it is necessary to compute the minimum  $C/N_0$  values for which the acquisition, tracking and data demodulation functions will fulfill the civil aviation requirements in operational scenarios, considering standard techniques and an airborne Galileo receiver with a reasonable complexity. The analysis presented in this paper will be based upon the methodologies proposed in the RTCA DO-235B [RTCA, 2008] (Assessment of Radio Frequency Interference Relevant to the GNSS L1 Frequency Band) and DO-292 [RTCA, 2004] (Assessment of Radio Frequency Interference Relevant to the GNSS L5/E5A Frequency Band) documents.

An initial computation of these thresholds was presented in [Julien et al, 2010] for Galileo E1 OS/SoL signal, taking into account the signal specific characteristics (new Composite Binary Offset Carrier (CBOC) modulation, different data rate, different data encoding and message structure, etc.). That article presented thresholds obtained

from a theoretical analysis. The present paper will provide refinements to these theoretical results as well as results based upon extensive simulations. Once the different thresholds are presented, they will be compared against worst-case link budgets to conclude on the suitability of the Galileo E1 OS signal to fulfill the civil aviation requirements of interest.

The outline of the paper is as follows: In section 2, the Galileo E1 OS signal acquisition (threshold and link budget) will be analyzed, followed in section 3 by the investigation of the Galileo E1 OS signal data demodulation (threshold and link budget), and finally, the Galileo E1 OS signal tracking study (threshold and link budget) will be presented. Section 5 will then gather the conclusions on the presented work.

## GALILEO E1 OS ACQUISITION THRESHOLD

The acquisition threshold is computed from a requirement on the initial acquisition time (time for the aircraft to compute its position with a predefined probability). The goal of this section is thus to provide an indicative, worst case, acquisition threshold value that should ensure that the requirement is met even for simplistic Galileo E1 receivers. It is important to keep in mind that the acquisition threshold itself does not constitute a requirement. It just has to be able to determine its position respecting the initial acquisition time requirement.

### Galileo Initial Acquisition Time Requirement

The current version of the Galileo MOPS is only a draft document and is designed for the use of the Galileo OS signal. In this draft there are now 2 initial acquisition time requirements: one for acquisition without any initialization, and one for acquisition with initialization. The following analysis only looks at the acquisition with initialization since it appears to be the more constraining one. It mentions that:

*"The acquisition time from application of power to the first valid position fix for either E5a, E5b or E1 shall be less than 5 minutes with a 95% probability under the following conditions. The receiver*

- shall be initialised to a latitude and longitude position within 60 nautical miles
- shall be initialised to within one minute of UTC time.
- shall be velocity aided within 30 m/s
- shall have valid almanac data and unobstructed satellite visibility
- will be subjected to the interference conditions of Appendix B

*In this context "valid" means all of the following conditions are met:*

- *The determined position meets the accuracy / integrity requirements for at least one minute following the first position fix."*

## Acquisition Threshold Computation Methodology

The methodology applied here reproduces the methodology used by the RTCA to assess the acquisition threshold of the GPS L1 C/A and the GPS L5 [RTCA, 2004; RTCA, 2008]. This methodology has however been adapted to the case of Galileo.

It is well-known that a minimum of 4 Galileo satellites has to be acquired in order to compute a first position. Once these 4 satellites have been acquired, it is then necessary to check the integrity of the computed position. Based on this, it seems fair to split the 5 min allocated time to the initial acquisition into [RTCA, 2004; RTCA, 2008]:

- 2.5 min for the acquisition of the first 4 satellites, and
- 2.5 min for the remaining tasks (verification, data demodulation, achievement of accuracy and integrity requirement

The acquisition of the first 4 satellites is here assumed to be sequential. It can thus be assumed that there is a specific acquisition time allocated to each satellite:  $T_i$  sec for the acquisition of the  $i^{\text{th}}$  satellite. Moreover, it is assumed that the receiver acquisition strategy is to first search for the satellite with the highest elevation angle (since the receiver is supposed to have access to the almanac, this is a likely strategy). Finally, the receiver is assumed to acquire each signal using a fixed duration, meaning that each acquisition bin is searched only once and that the decision for acquisition is taken once and for all after each bin has been searched. As a consequence, the receiver spends exactly  $T_i$  sec to search for the  $i^{\text{th}}$  satellite.

The acquisition of the first satellite is clearly the most difficult one since there is the largest uncertainty in the Doppler value [RTCA, 2004]. Once the first satellite has been acquired, there is a significant reduction of the Doppler uncertainty for the remaining satellites since it is then possible to estimate the bias between the expected Doppler computed using the almanac and the actual acquired Doppler. It is then easier to acquire the 2<sup>nd</sup>-4<sup>th</sup> satellites. To take that into account, and to simplify the methodology, only 2 acquisition time allocations are considered:

- the acquisition time of the 1<sup>st</sup> satellite:  $T_1$ , and
- the acquisition time of each of the remaining satellites:  $T_4$ .

Taking into account (a) the satellite selection strategy, (b) the receiver acquisition methodology described earlier, and (c) assuming that the acquisition of each satellite is independent, the probability of acquisition  $P_{Acq}$  within 2.5 min of the first 4 satellites can be decomposed into:

$$P_{Acq} = P_{Acq1} \cdot P_{Acq2} \cdot P_{Acq3} \cdot P_{Acq4} \quad \text{Eq. 1}$$

where  $P_{Acqn}$  represents the acquisition probability to acquire satellite  $n$  within its allocated time. It can be decomposed as follows, using conditional probability:

$$P_{Acq,n} = \int_{-\infty}^{+\infty} P_{d,n}(x) \cdot P(x) dx$$

with :

- $P_{d,n}(x)$  is the probability of acquiring satellite  $n$  with a  $C/N_0$  equal to  $x$  within its allocated time using the aforementioned receiver strategy,
- $P(x)$  is the probability that the  $C/N_0$  of the  $n$ -th satellite is equal to  $x$ .

Considering the Galileo E1 passive antenna gain model provided in Table 1, it is clear that the acquisition of the 4<sup>th</sup> satellite will be more difficult than the acquisition of the 2<sup>nd</sup> and 3<sup>rd</sup> satellites since it will be assigned the same acquisition time although it has a lower elevation and thus a lower received  $C/N_0$ . As a consequence, considering Eq. 1,  $P_{Acq}$  can be lower-bounded by:

$$P_{Acq} > P_{Acq1} \cdot (P_{Acq4})^3 \quad \text{Eq. 2}$$

**Table 1 – Passive Antenna Model Gain Limits**

| Elevation Angle | Min Gain (dBic)  | Max. Gain (dBic)   |
|-----------------|------------------|--------------------|
| [75°; 90°]      | +0.5             | +3                 |
| [20°; 75°]      | -1+0.0231×(e-20) | +2.5+0.0077×(e-10) |
| [10°; 20°]      | -7+0.3×e         | +2.5+0.0077×(e-10) |
| [0°; 10°]       | -7+0.3×e         | -2+0.45×e          |

Note: e is the elevation angle in °

Considering the worst case scenario where  $(C/N_0)_{min,n}$  represents the lowest  $C/N_0$  possible for the  $n^{\text{th}}$  satellite,  $P_{Acq}$  can be lower-bounded by:

$$P_{Acq} > P_{d,1} \left( (C/N_0)_{min,1} \right) P_{d,4}^3 \left( (C/N_0)_{min,4} \right) \quad \text{Eq. 3}$$

Regarding the initial acquisition time requirement, and assuming that the verification phase will always be successful (this will be confirmed by the high threshold values that will be found later on), it is then necessary to have  $P_{Acq} \geq 0.95$ . To ensure this, it is required to target probability values in Eq. 3 that fulfill  $P_{Acq} \geq 0.95$ . For instance, it is proposed to find a value of  $C/N_0$ , referred to as  $(C/N_0)_{TH}$ , lower than  $(C/N_0)_{min,1}$  and  $(C/N_0)_{min,n}$  that is such that:

$$\begin{cases} P_{d,1} \left( (C/N_0)_{TH} \right) = 0.98 \\ P_{d,2-4} \left( (C/N_0)_{TH} \right) = 0.99 \end{cases} \quad \text{Eq. 4}$$

If this value exists, then  $P_{Acq} > 0.98 \cdot 0.99^3 = 0.9509 > 0.95$ .  $(C/N_0)_{TH}$  could then be considered as the acquisition threshold. The

difference between  $(C/N_0)_{TH}$  and  $\min \left\{ (C/N_0)_{min,1}, (C/N_0)_{min,4} \right\}$  can then be considered as a safety margin.

### Computation of the Acquisition Threshold

It is now necessary to ensure that Eq. 4 can be fulfilled. The idea here is to look at a minimalist receiver architecture that has a simple acquisition structure based on a single dwell method using a Neyman-Pearson test.

The theory of the Neyman-Pearson acquisition technique is very well documented and will not be fully repeated here. In this section, the case of an acquisition based on the data and pilot components of the Galileo E1 OS signal is considered. Indeed [RTCA, 2004] showed for GPS L5 that it was more efficient than acquisition based on the pilot channel only due to the presence of the secondary code.

### Signal and Receiver Considerations

The Galileo E1 OS has the following characteristics: its waveforms are a CBOC(6,1,1/11, '+') on the data channel and a CBOC(6,1,1/11, '-') on the pilot channel. The power share between the data and pilot components is 50%/50% [EC, 2010].

The considered receiver is a minimalist receiver referred to as a BOC(1,1) receiver: it has an equivalent front-end filter bandwidth equal to 4 MHz (double-sided) and generates locally only a BOC(1,1) replica [Julien, 2005] on both the data and pilot components.

### Correlator Output Model

The correlator output model is extrapolated from [Bastide, 2004] for GPS L5 to the case of Galileo E1 OS:

$$S_{I,D}(k) = G \left[ S_{I,D}(k) R^*(D,D) (c_P) \otimes - d_P \right] \quad \text{E 9}$$

with

$$R_{R,Y}(x) = (R_{R,Y} \otimes h)(x) = \int_{-\infty}^{+\infty} H(f) F_R(f) F_Y^*(f) e^{-2j\pi f x} df$$

$$\beta_N = \int_{-\infty}^{+\infty} |H(f)|^2 |F_Y(f)|^2 df$$

is the loss of noise power due to the front-end filter  $H$  and the local waveform  $Y$ .

$$G = \frac{\sqrt{P}}{2} \text{sinc}(\pi s_f T_I)$$

where

- $c_P$  and  $c_D$  are the spreading sequences carried by the pilot and data components, and
- $S_{C_P}$  and  $S_{C_D}$  are the sub-carriers carried by the pilot and data components
- $h$  and  $H$  are the equivalent front-end filter impulse response and transfer function respectively,

- $F_X$  is the Fourier transform of the signal  $X$ ,
- $R_{XY}$  is the correlation function between the incoming spreading sequence  $X$  and the locally generated spreading sequence  $Y$
- $\hat{R}_{XY}$  is the correlation function between the incoming spreading sequence  $X$  and the locally generated spreading sequence  $Y$  taking into account the front-end filter  $H$
- $\beta_X$  represents the loss of noise power due to the front-end filter  $H$  and the local waveform  $Y$ .
- $\varepsilon_\tau = \tau - \hat{\tau}$  is the code delay error
- $\varepsilon_\varphi = \varphi - \hat{\varphi}$  is the phase error
- $\varepsilon_f = f_D - \hat{f}_D$  is the frequency error
- $n_{I_D}, n_{Q_D}, n_{I_F}$ , and  $n_{Q_F}$  are the noise components of the 4 discriminator outputs respectively. They are uncorrelated, and, assuming that the receiver generates the same local replica for the data and pilot components, then

$$\text{Var}[n_{I_D}] = \text{Var}[n_{Q_D}] = \text{Var}[n_{I_F}] = \text{Var}[n_{Q_F}] = \frac{N_0}{4T_i} \beta_D = \frac{N_0}{4T_i} \beta_F$$

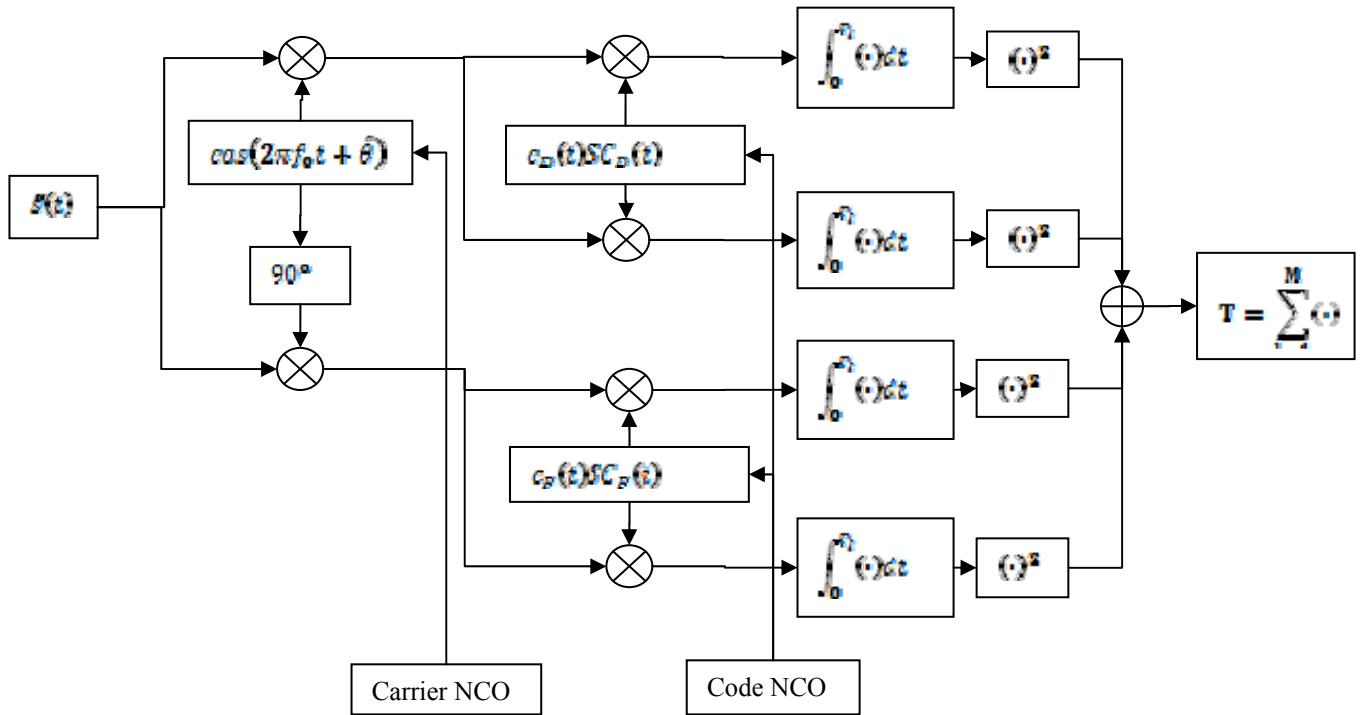

Figure 2 – Acquisition Architecture

### Acquisition Architecture

The typical architecture for acquisition when receiving a signal with data and pilot components is shown in Figure 2 [Bastide et al, 2004; RTCA, 2004]. It consists in the use of 2 complex correlators: 1 for the data channel and 1 for the pilot channel.

The acquisition detector is then:

The correlation functions  $\hat{R}_{D,D}$  and  $\hat{R}_{P,P}$  have the shape shown in Figure 1.

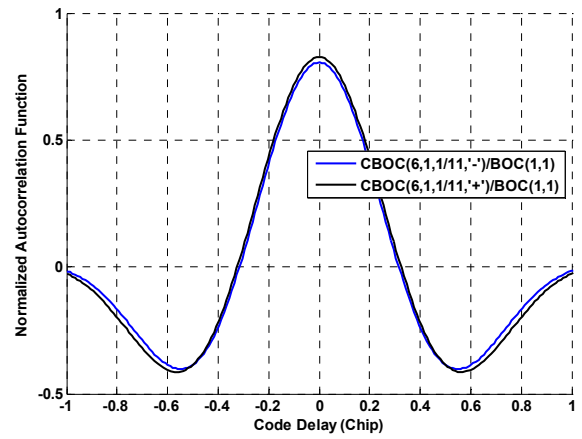

Figure 1 – Correlation of a BOC(1,1) local replica with the Galileo E1 OS Signal

$$T = \sum_{i=1}^M (I_D^2(k) + Q_D^2(k) + I_P^2(k) + Q_P^2(k)) \quad \text{Eq. 6}$$

where  $M$  is referred to as the number of non-coherent summations.

The approach followed herein is the Neyman-Pearson's approach that is based on an hypothesis test:

- Hypothesis  $H_0$ : the useful signal is absent, but an interfering signal is present
- Hypothesis  $H_1$ : the useful signal is present

### Detection Threshold

Let us assume that the useful signal is absent, but that there is an interfering signal from the same constellation as the desired signal. Moreover, this interfering signal will be assumed perfectly aligned with the local replica (in terms of frequency and delay offset) so as to generate the highest cross-correlation peak possible. Thus  $\bar{T}_0$  has a non-central Chi-square distribution with  $4M$  degrees of freedom and a non-centrality parameter equal to:

$$\bar{\lambda}_0 = (P_I T_I) / (\beta_D N_0) \sum_{k=1}^M \left[ (R_{D,D}^2(\epsilon_T))^2 + (R_{P,P}^2(\epsilon_T))^2 \right]$$

where  $P_I$  is the power of the interferer

For a spreading sequence with a chipping rate of 1.023 Mcps (the chipping rate used by Galileo E1 OS), and considering the worst case signal dynamics, it is possible to assume that the incoming signal characteristics do not change during a duration of several hundreds of milliseconds. It is here assumed that these signal characteristics do not change during the acquisition dwell time  $MT_I$ . Moreover, it will be assumed that the successive values of  $d_{D,T}$  and  $d_{S,T}$  are random, uncorrelated and have a zero mean value. Note that this last assumption is quite strong since in reality, the number of non-coherent summations is very limited. Then:

$$\bar{\lambda}_0 = MT_I \cdot \frac{P_I}{N_0} \cdot \frac{1}{\beta_D} \cdot \left( (R_{D,D}^2(0) + R_{P,P}^2(0)) + (R_{D,D}^2(0) + R_{P,P}^2(0)) \right)$$

Knowing the distribution of the random variable  $\bar{T}_0$ , it is then easy to find the threshold  $Th$  such that  $P(\bar{T}_0 > Th) = P\left(T_0 > Th \cdot \frac{N_0}{4T_I} \beta_D\right) = P_{fa}$  for a desired probability of false alarm  $P_{fa}$ .

### Probability of Detection

Let us now assume that the useful signal is present. In this situation, since we are interested in locating the maximum of the useful signal correlation function, it is possible to consider that  $R_{D,D}(\epsilon_T) \gg R_{P,D}(\epsilon_T)$  and  $R_{P,P}(\epsilon_T) \gg R_{D,P}(\epsilon_T)$  for  $\epsilon_T \ll 1$ . In this case,  $\bar{T}_1$  has a non-central Chi-square distribution with  $4M$  degrees of freedom and a non-centrality parameter equal to:

$$\bar{\lambda}_1 = \frac{PT_I}{\beta_D N_0} \sum_{k=1}^M \left( \text{sinc}^2(\pi \epsilon_T T_I) (R_{D,D}^2(\epsilon_T) + R_{P,P}^2(\epsilon_T)) \right)$$

This can be rewritten as:

$$\bar{\lambda}_1 = T_I \cdot \frac{P}{N_0} \cdot \frac{R_{D,D}^2(0) + R_{P,P}^2(0)}{\beta_D} \cdot \sum_{k=1}^M \text{sinc}^2(\pi \epsilon_T T_I) \cdot \left( \frac{R_{D,D}^2(\epsilon_T) + R_{P,P}^2(\epsilon_T)}{R_{D,D}^2(0) + R_{P,P}^2(0)} \right)$$

Once  $M_{i,max}$  has been computed, it is then possible to compute the probability of detection of the satellite as a function of the incoming  $C/N_0$  and the number of complex correlators using the methodology previously exposed.

Using the same assumptions as for hypothesis  $H_0$ , then:

$$\bar{\lambda}_1 = 2MT_I \frac{P}{N_0} \cdot L_{Corr} \cdot L_{Imc}(\epsilon_T) \cdot \text{sinc}^2(\pi \epsilon_T T_I) \quad \text{Eq. 7}$$

where

- $L_{Imc} = \frac{R_{D,D}^2(\epsilon_T) + R_{P,P}^2(\epsilon_T)}{R_{D,D}^2(0) + R_{P,P}^2(0)}$  represents the incremental losses, which means the losses due to the code delay error, and
- $L_{Corr} = \frac{R_{D,D}^2(0) + R_{P,P}^2(0)}{2\beta_D}$  represents the acquisition-specific correlation losses, which means the  $C/N_0$  losses due to the correlation process.

It can be seen from Eq. 7 that the non-central parameter will depend upon a number of factors:

- The received signal  $C/N_0$ ,
- The coherent integration time  $T_I$ ,
- The number of non-coherent summations  $M$ ,
- The front-end filter through  $L_{Imc}$  and  $L_{Corr}$ , and
- The misalignments  $\epsilon_T$  and  $\epsilon_f$ .

Knowing the distribution of the random variable  $\bar{T}_1$ , it is then easy to find the probability of detection  $P_d$  since that  $P(\bar{T}_1 > Th) = P\left(T_1 > Th \cdot \frac{N_0}{4T_I} \beta_D\right) = P_d$ .

### Computation of the Acquisition Threshold

From previous sections, it is known that the receiver has  $T_i$  sec to acquire the  $i^{\text{th}}$  satellite and that the receiver is assumed to search every bin of the uncertainty space only once. Thus, it is necessary that each bin of the search space is visited once within  $T_i$  sec. Moreover, it has to be kept in mind that with the data/pilot acquisition architecture used here, 2 complex correlators are necessary to search one bin. This means that the maximum number of non-coherent summations equals:

$$M_{i,max} = \left\lfloor \frac{NT_i}{2 \cdot \left| \frac{\Delta C}{\beta_C} \right| \cdot \left| \frac{\Delta D}{\beta_D} \right| \cdot T_i} \right\rfloor$$

where

- $\Delta C$  and  $\Delta D$  are the code delay and Doppler uncertainty,
- $\beta_C$  and  $\beta_D$  are the widths of the code delay and Doppler bins,
- $N$  is the number of complex correlators available in the receiver.



It is also important to take into account the incremental losses present in Eq. 7 to compute the real probability of detection. To do so, [RTCA, 2008] proposes to take the expected probability of detection considering that the code delay and Doppler errors are uniformly distributed within the search bin:

$$\bar{P}_d = E[P_d(\sigma_r, \sigma_f)]_{\sigma_r \sim \left[-\frac{0.9 \text{ dB}}{2}, \frac{0.9 \text{ dB}}{2}\right], \sigma_f \sim \left[-\frac{0.9 \text{ Hz}}{2}, \frac{0.9 \text{ Hz}}{2}\right]}$$

### Assumptions Regarding the Acquisition Strategy Code and Doppler Bin Size

The coherent integration time is taken equal to the length of the spreading code: 4 ms. This is dictated by the fact that the data and pilot components are modulated by the navigation message and the secondary code respectively, which have both a rate of 250 Hz [EC, 2010].

The spreading code is 4092-chip long. Since the slope of the correlation function central peak is about 3 times higher than that of the GPS C/A (see Figure 1), it seems natural to select a code delay bin width 3 times smaller than that of standard GPS C/A acquisition. Consequently, it was decided to take a code delay bin width of 1/6 of a chip. A code delay bin width of 1/4 of a chip will also be tested since it provides incremental losses that are comparable to those of a GPS C/A with a 2-MHz equivalent front-end filter bandwidth [RTCA, 2008].

Due to the coherent integration duration of 4 ms, the Doppler bin width is chosen equal to 125 Hz (meaning a maximum degradation of 0.9 dB). The uncertainty on the Doppler is taken as in [RTCA, 2008]:

- The main contributor to the Doppler uncertainty is (1) the receiver oscillator when the plane is on the ground, and (2) the aircraft dynamics when the plane is en-route (assumed to have stored the oscillator bias/drift before the short power outage):
  - On the ground, it results in a Doppler uncertainty of +/-1500 Hz. This case is kept as it is used in [RTCA, 2008], although it does not fit with the en-route acquisition scenario. It will be referred to as "on-the-ground case"
  - En-route, it results in a Doppler uncertainty of +/-250 Hz. It will be referred to as "en-route case"
- Once the 1<sup>st</sup> satellite has been acquired, the Doppler uncertainty drops to +/-150 Hz in both cases.

The resulting number of bins to search is reported in Table 2.

**Table 2 – Number of Galileo E1 OS Acquisition Search Bins**

|   | On-the-Ground Case | En-route Case |
|---|--------------------|---------------|
| Doppler Uncertainty - 1 <sup>st</sup> sat | +/- 1500 Hz        | +/-250 Hz     |
| Doppler bin size                          | 125 Hz             | 125 Hz        |
| Nb of Doppler bins - 1 <sup>st</sup> sat  | 24                 | 4             |
| Nb of code delay bins                     | 24552              | 24552         |
| Total nb of cells – 1 <sup>st</sup> sat   | 589248             | 98208         |
|   |                    |               |

|                               |            |           |
|-------------------------------|------------|-----------|
| Doppler Uncertainty – 2-4 sat | +/- 150 Hz | +/-150 Hz |
| Doppler bin size              | 125 Hz     | 125 Hz    |
| Nb of Doppler bins – 2-4 sat  | 3          | 3         |
| Nb of code delay bins         | 24552      | 24552     |
| Total nb of cells – 2-4 sat   | 73656      | 73656     |

### Acquisition Time Allocation

The satellite acquisition time allocation is chosen to be approximately proportional to the number of bins to search. This is different from the RTCA approach where the allocated times seemed fixed.

In the "on-the-ground" case, the allocated acquisition durations are chosen to be equal to:

- 105 sec to acquire satellite 1
- 15 sec to acquire satellite 2, 3, and 4.

In the "en-route" case, the allocated acquisition durations are chosen to be equal to:

- 45 sec to acquire satellite 1
- 35 sec to acquire satellite 2, 3, and 4.

### Worst Case Cross-Correlation from an Interfering Signal

In order to determine the worst-case cross-correlation interference from another Galileo E1 OS signal, it is necessary to determine the level of the highest cross-correlation peak at the correlator output as well as the worst case power of the interferer.

[EC, 2010] mentions that the maximum power level received at 5° elevation is 3dB higher than -157.25dBW. Moreover, according to Table 1, the maximum antenna gain for a satellite at the zenith is +3dBi. Consequently, the most powerful received signal should have a received post-correlation C/N<sub>0</sub> equal to 47.55 dB-Hz, according to the associated link budget. Note that this link budget takes into account:

- the implementation losses composed of
  - 1-bit quantization losses (1.6 dB), and
  - correlation losses computed from Eq. 5 (1.1 dB),
- a post-correlation N<sub>0</sub> computed based on the scenario described later on.

Regarding the highest Galileo E1 OS cross-correlation peak, [Wallner et al, 2006] provides the following cross-correlation properties of the Galileo E1 OS codes:

- the highest cross-correlation (CC) peak has a magnitude of -23.6 dB
- 99.9999% of the CC peaks are below -24.7dB
- 99.999% of the CC peaks are below -25.5dB
- 99.99% of the CC peaks are below -26.5dB
- 99.9% of the CC peaks are below -27.8dB, and
- 99% of the CC peaks are below -29.5dB.

Consequently, the value of -23.6 dB will be taken in the following, although it is clearly a worst case.

### Desired Probability of False Alarm

The probability of false alarm was chosen as the inverse of the length of the spreading code, or approximately  $2.5e^{-4}$ .

### Acquisition Results

Table 3 presents the minimum required post-correlation  $C/N_0$  values that are necessary to acquire the satellite with a given probability of detection based on the methodology defined earlier, assuming the receiver settings presented earlier, and for the "on-the-ground" case. This case can be seen as a worst case as it assumes that the receiver clock drift has not been estimated and stored before the power failure. Table 3 shows the results obtained using a code delay bin width of 1/6 and 1/4 of a chip.

The values of post-correlation  $C/N_0$  that are of interest to decide upon an acquisition threshold are the ones that use an acceptable number of correlators. Based on a similar analysis realized in [RTCA, 2004] for a GPS L5 receiver, it seems that about 200 complex correlators could be acceptable, although this should be checked with receiver manufacturers. This, however, seems reasonable as Galileo E1 OS receivers would probably go in the market around 2018-2020. Table 3 provides two interesting results with regards to this:

- First, it can be seen that the use of a code delay bin width of 1/4 of a chip provides a lower acquisition threshold (by approximately 1 dB) than using a value of 1/6 of a chip for the same number of complex correlators.
- Second, it shows that with a code delay bin of 1/4 of a chip, the acquisition threshold would be approximately 34 dB-Hz using 200 complex correlators in the "on-the-ground" case.

**Table 3 - Galileo E1 OS Acquisition Threshold as a Function of the Number of Complex Correlators ("On-the-ground" Case)**

| Nb of Complex Correlators | Code Delay Bin Width = 1/6 Chip                       |  | Code Delay Bin Width = 1/4 Chip                       |  |
|---------------------------|---|--|---|--|
|                           | 1 <sup>st</sup> sat.<br>105-s acq.<br>time<br>Pd=0.98 | 2-4 <sup>th</sup> sat.<br>15-s acq.<br>time<br>Pd=0.99 | 1 <sup>st</sup> sat.<br>105-s acq.<br>time<br>Pd=0.98 | 2-4 <sup>th</sup> sat.<br>15-s acq.<br>time<br>Pd=0.99 |
| 100                       | 36.8  | 37.1   | 35.8  | 36.1   |
| 150                       | 35.5  | 35.8   | 34.4  | 34.8   |
| 200                       | 34.8  | 34.5   | 34  | 33.9   |
| 300                       | 33.7  | 33.6   | 32.8  | 32.8   |

The results for the "en-route" case are shown in Table 4. Because the Doppler uncertainty on the 1<sup>st</sup> satellite is lower, this means that the acquisition threshold could be lowered compared to the "on-the-ground" case. For instance:

- assuming a receiver with the same value of 200 complex correlators, the proposed acquisition

threshold could now be around 32 dB-Hz, instead of 34 dB-Hz as in the "on-the-ground" case.

- An acquisition threshold of 34 dB-Hz would only necessitate around 100 complex correlators.

It is important to note that the results provided are strongly affected by the level of the worst case cross-correlation peak. In reality, it is extremely unlikely that one of the interfering signals provide both the highest cross-correlation and is at the zenith. For instance, it has to be kept in mind that 99.99% of the cross-correlation peaks generated by all Galileo E1 OS codes are about 3 dB below the worst case used in the previous analysis. Taking this into account would contribute to lower the proposed acquisition threshold for a specific number of correlators, or to lower the number of correlators to reach a predefined threshold. Indeed, it might not be necessary to dimension the detection threshold based on a worst-case cross-correlation peak that is so unlikely. As an example, the case of a worst-case cross-correlation peak at -26.5 dB (2.9 dB below the worst case used for Table 3 and Table 4) has been analyzed for the "en-route" case and a code delay bin width of 1/4 of a chip. It was observed that the resulting required post-correlation  $C/N_0$  for fulfilling the initial acquisition time requirement was lowered by 0.5 to 1 dB compared to the previous case.

**Table 4 - Galileo E1 OS Acquisition Threshold as a Function of the Number of Complex Correlators ("En-Route" Case)**

| Nb of Complex Correlators | BOC Receiver (Code Delay Bin Width = 1/6 Chip)       |  | BOC Receiver (Code Delay Bin Width = 1/4 Chip)       |  |
|---------------------------|--|--|--|--|
|                           | 1 <sup>st</sup> sat.<br>45-s acq.<br>time<br>Pd=0.98 | 2-4 <sup>th</sup> sat.<br>35-s acq.<br>time<br>Pd=0.99 | 1 <sup>st</sup> sat.<br>45-s acq.<br>time<br>Pd=0.98 | 2-4 <sup>th</sup> sat.<br>35-s acq.<br>time<br>Pd=0.99 |
| 50                        | 36.6   | 36.9   | 35   | 35.3   |
| 100                       | 34.1   | 34.4   | 33.3   | 33.6   |
| 150                       | 32.9   | 33.2   | 32.4   | 32.5   |
| 200                       | 32.2   | 32.4   | 31.6   | 31.9   |

### Description of the Considered Scenario and Associated Link Budget

Now that the acquisition threshold has been investigated, it is necessary to confront the retained acquisition threshold values to the case of operational scenarios. RTCA defines several scenarios-of-interest in [RTCA, 2008]: En-route acquisition scenario, high and medium altitude en-route/terminal area tracking and data demodulation scenario, GNSS Non-Precision Approach (LNAV) scenario, GNSS Cat I Precision Approach, GNSS Cat II/III Precision Approach

Each of these scenarios have the particularity to have specific Radio-Frequency Interference (RFI) encounter scenarios. For all these scenarios, a specific link budget is



drawn and compared to the threshold to ensure a positive margin. Regarding the acquisition case, though, it can be seen that retained scenario considers the aircraft en-route. This makes sense since a power loss during a landing phase or a terminal approach would probably lead either to a missed approach or to an approach without GNSS. In this case, the aircraft would go back to a higher altitude that would allow enough time for acquisition. Consequently, only the en-route scenario is considered in this section.

### En-Route Scenario and Interference Environment

[RTCA, 2008] describes an en-route acquisition scenario where the aircraft is at an altitude of 18,000 feet (5.5 km) with a normal behavior and for a sufficient time so that it has stored satellite ephemeris, aircraft position and velocity, and receiver clock bias/drift. This state is then interrupted for a short time (e.g. power failure) and the receiver must re-establish navigation in “warm start” mode.

[RTCA, 2008] has specifically analyzed the aircraft interference environment considering the aforementioned scenario. It has been shown that the RF interference environment to consider is composed of:

- the inter- and intra- system interference,
- on-board installed avionics emissions,
- On-board Aeronautical Mobile Satcom. This is assumed present en-route, but turned off on the ground and during precision approach.
- Non-aeronautical Portable Electronic Device aggregate power (that include a 6 dB aeronautical margin),
- Pulse RFI with a 1% duty cycle.

The equation used to compute the resulting equivalent noise is given by:

$$N_{0,eff} = \frac{N_0 \left(1 + \frac{I_{0,WB}}{N_0}\right)}{1 - PDC_{lim}}$$

where

- $I_{0,WB}$  is the total wideband equivalent continuous RFI power spectral density,
- $PDC_{lim}$  is the fractional duty cycle of the saturating pulses

The intra-system interference analysis has not been done thoroughly for the Galileo case. Instead, the equivalent  $N_0$  generated by the inter- and intra-system interference was approximated to -199 dBW/Hz.

As a result, the equivalent  $N_0$  associated to the acquisition scenario is assumed equal to -196.3 dBW/Hz.

### En-Route Acquisition Link Budget

Based on the interference environment analysis just above, considering the passive antenna gain pattern in Table 1, and considering [EC, 2010], it is possible to compute the link budget associated with the en-route acquisition scenario. Two cases are considered: the case of the minimum elevation of the highest satellite, and the

case of the minimum elevation of the fourth highest satellite. Simulations considering a 27-satellite Galileo constellation with 2 coincident satellite failures showed that these minimum elevation were around 48° and 18°, respectively.

[EC, 2010] mentions a minimum received power for the E1 OS signal of -157 dB "measured at the output of an ideally matched RHCP 0 dBi polarized user receiving antenna when the SV elevation angle is higher than 10 degrees". In addition, it is mentioned that "For a 5 degree user elevation angle, the user minimum received power will typically be 0.25 dB lower".

The resulting link budget is shown in Table 5. It represents the minimum post-correlation  $C/N_0$  that should be received assuming the considered scenario.

Table 5 shows that an acquisition threshold of 34 dB-Hz is acceptable since the worst-case post-correlation  $C/N_0$  values are above 34 dB-Hz. The margin would then be around 0.65 dB, which might appear slim, but considering all the approximations, it appears fairly safe.

**Table 5 – Galileo E1 OS Link Budget for Minimum Acquisition Received Power**

| Line Nb | Parameter (Units)  | 1 <sup>st</sup> SV Acq (48°) | 4 <sup>th</sup> SV Acq (18°) |
|---------|--|------------------------------|------------------------------|
| 1       | Surface Satellite Signal Power (dBW)   | -157.25                      | -157.25                      |
| 2       | Minimum Antenna Gain (dB)  | -0.6                         | -1.6                         |
| 3       | Implementation Loss (dB) <ul style="list-style-type: none"> <li>• AGC+quantization = 1.6 dB;</li> <li>• Correlation loss (BOC(1,1) in 4 MHz) = 1.2 dB (Eq. 7)</li> </ul> | -2.8                         | -2.8                         |
| 4       | C = Recovered SV Carrier Power (dBW) ((1)+(2)-(3))   | -160.65                      | -161.65                      |
| 5       | $N_{0,eff}$ (dBW/Hz)   | -196.3                       | -196.3                       |
| 6       | <b>Post-Correlation <math>C/N_0</math> (dB-Hz) ((4)-(5))</b>   | <b>35.65</b>                 | <b>34.65</b>                 |

## GALILEO E1 OS DATA DEMODULATION THRESHOLD

### Civil Aviation Operational Requirements

The current requirements written in the Galileo MOPS is for the en-route, oceanic and NPA phase-of-flights. It mentions that:

*For GALILEO E1 data channel: The coded and interleaved Navigation Data Message Stream for E1 signal (I/NAV) is transmitted at 250 symbols/second on the E1B data channel. The E1 GALILEO message word error rate shall be less than  $10^{-3}$ "*

## Receiver Specifications

As in the case of the acquisition, the receiver is assumed to be a minimalist receiver: a 4-MHz BOC receiver.

Data demodulation will greatly depend upon phase tracking accuracy since phase lock is necessary for data demodulation. In the following, the receiver is assumed to track the Galileo E1 OS signal based only upon its pilot component [Hegarty, 1999; Julien, 2005]. The data demodulation is then realized by using a specific in-phase correlator on the data demodulation that is completely driven by the code delay and phase tracking loops associated to the pilot component.

The PLL is assumed to be of the 3<sup>rd</sup> order, to have an equivalent loop bandwidth  $B_L$  equal to 10 Hz, and to be implemented according to [Stephens and Thomas, 1995].

## Sources of Errors Affecting the PLL

This section only reminds the different sources of phase tracking errors and the associated values applying to the present analysis. More information can be found in [Hegarty, 1997; Irsigler and Eissfeller, 2002; Julien, 2005].

### Thermal Noise

The impact of thermal noise on phase tracking can be modeled by a white Gaussian noise with a variance equal to:

$$\sigma_{\varepsilon_{th}}^2 = \frac{2B_L}{C} \left( \text{rad}^2 \right) \frac{1}{N_0}$$

Note that in the above equation, the  $C/N_0$  represents the post-correlation  $C/N_0$  associated to the whole signal (data+pilot).

### Oscillator Phase Noise

[EC, 2010] specifies that the phase noise spectral density of the un-modulated carrier will allow a second-order PLL with a 10 Hz one-sided noise bandwidth to track the carrier to an accuracy of 0.04 radians RMS. In the present case, this same value will be used, although a 3<sup>rd</sup> order PLL is considered.

The receiver is assumed to use a stable Temperature-Compensated Crystal (TCXO). The induced tracking jitter standard deviation for the specified PLL is 0.0873 rad (5°).

[Irsigler and Eissfeller, 2002] provides a model to compute the phase tracking jitter due to the vibration of the oscillator. Following this model, the resulting phase tracking jitter standard deviation is 0.0593 rad.

Assuming that all these clock-related terms are independent, the total oscillator phase noise jitter standard deviation will be taken equal to  $\sigma_{\varepsilon_{osc}} = 0.1129 \text{ rad}$

### Dynamics

For our specific case, the maximum jerk during normal commercial aircraft manoeuvres equals 0.25g/s. The effect of a constant jerk on a 3<sup>rd</sup> order PLL will be a

tracking bias  $\gamma$ . This bias can be computed according to [Stephens and Thomas, 1995]. This provides a bias  $\gamma = 0.1713 \text{ rad}$ .

### Multipath

No multipath is considered here, as the aircraft is assumed at high or medium altitude.

## Theoretical Investigation of the Data Demodulation Performance

The structure of the Galileo I/NAV message is detailed in [EC, 2010]. The useful message has a bit rate of 125 bps and is encoded using a convolutional coding of constraint 7 with a rate of 1/2 and then interleaved. The transmitted symbol rate is then 250 sps.

Considering that the symbols are binary, the Symbol Error Rate (SER) considering a phase tracking error  $\varepsilon_\varphi$  is given by [Hegarty, 1997]:

$$P_s(\varepsilon_\varphi) = \frac{1}{2} \text{erfc} \left( \sqrt{\frac{E_s}{N_0}} \cos(\varepsilon_\varphi) \right) \quad \text{Eq. 8}$$

where  $E_s = \frac{C}{2} T_i$  is the symbol energy in the case of Galileo E1 OS since the message is only present on the data component.

Consequently, the mean SER for the Galileo receiver can be estimated using the expectation computation:

$$\text{SER} = \int_{-\pi}^{\pi} P_s(x) f_{\varepsilon_\varphi}(x) dx \quad \text{Eq. 9}$$

where  $f_{\varepsilon_\varphi}$  represents the probability density function of the phase tracking error  $\varepsilon_\varphi$ .

To solve for Eq. 9,  $f_{\varepsilon_\varphi}$  can be approximated by a Gaussian function in the following way:

$$f_{\varepsilon_\varphi}(x) = \frac{1}{\sqrt{2\pi}\sigma_{\varepsilon_\varphi}} e^{-\frac{(x-\gamma)^2}{2\sigma_{\varepsilon_\varphi}^2}}$$

Assuming soft decoding using a Viterbi decoder, the Bit Error Rate (BER) may then be upper bounded using [Hegarty, 1997]:

$$P_b(\varepsilon_\varphi) = \frac{1}{2} (36D^{10} + 211D^{12} + 1404D^{14} + 11) \quad \text{Eq. 10}$$

with  $D = e^{-\frac{1.5E_s}{2N_0} \cos^2(\varepsilon_\varphi)}$

Using Eq. 10, the mean BER for the Galileo receiver can then be estimated using:

$$\text{BER} = \int_{-\pi}^{\pi} P_b(x) f_{\varepsilon_\varphi}(x) dx$$

Finally, it is necessary to define what a Galileo E1 OS word is in order to compute the WER. The Galileo E1 OS I/NAV message structure is composed of pages that are

sub-divided into 2 sub-pages. Each subpage (referred to as odd and even) contain 120 bits (240 symbols after coding) and 10 preamble symbols (not coded by the convolutional code). A CRC of length 24 bits is used to protect the first 202 bits (excluding the preamble symbols) across the odd and even pages. In the following, we will thus consider that a word is composed of the bits protected by the CRC. It is thus composed of 202 bits.

The resulting WER can be computed, assuming that the bit errors are uniformly distributed, using:

$$WER = 1 - (1 - BER)^N$$

where  $N$  is the number of bits composing the word.

The BER and WER theoretical results as a function of the post-correlation  $C/N_0$  ( $C$  representing the total Galileo E1 OS power) value are shown in Figure 3 for a worst case dynamics equal to 0.25g/s and the case without dynamics. It can be seen that for a targeted WER of  $10^{-3}$ , the data demodulation threshold is between 29.3 and 30.5 dB-Hz.

However, it also seems necessary to realize extensive simulations to verify the figures plotted in Figure 3. Indeed, it is noted in the literature [RTCA, 2004; RTCA, 2008] that it is very difficult to estimate the WER from the BER due to the occurrence of burst errors or due to the actual data structure. Moreover, the BER itself could be not well represented due to the use of an upper bounding and approximations linked to the choice of  $f_{z\sigma}$ .

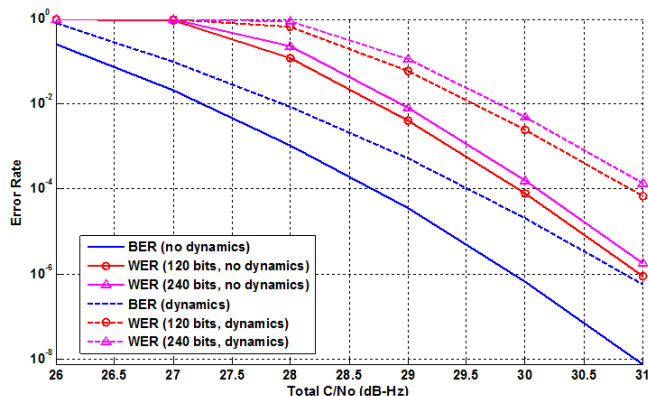

Figure 3 - Theoretical BER and WER for the Galileo E1 OS/SoL Signal

### Investigation of the Data Demodulation Performance Through Simulation

As mentioned earlier, it was decided to use extensive simulations to confirm the BER and WER values provided earlier. For this purpose two different tools were used:

- a behavioral receiver that simulates the functioning of a GNSS receiver, and provides the correlator outputs that will be used for demodulation, and
- a Galileo E1 OS message modulator/demodulator that generates a message based on [EC, 2010], provides it to the behavioral receiver, and then demodulates the correlator outputs provided by the behavioral receiver to test if the demodulated bit or word is correct.

### Presentation of the Tools

#### Receiver

The receiver used is a behavioral receiver that only models the received signal at the correlator level based on an input file providing the incoming signal delay, phase and  $C/N_0$ . The receiver is written in C language and has the following capabilities (this is not an exhaustive list):

- Generation of user-specified range variation to simulate any kind of dynamics
- User-defined  $C/N_0$
- Tracking of GPS L5, L1 C/A, Galileo E1 (BOC and CBOC), E5a, E5b
- Tracking of CBOC with a BOC receiver,
- Setting of the front-end filter equivalent bandwidth
- Generation of correlated noise between the different correlator outputs
- Generation of oscillator phase error (Quartz, TCXO, OCXO, Rubidium)

Specifically for the simulations, the receiver settings were the same for all the simulations:

- BOC receiver receiving the Galileo E1 OS pilot component only
- 4-MHz front-end equivalent bandwidth (double-sided)
- The PLL uses an Atan2 discriminator, has a 10-Hz loop bandwidth and is based on a 20-ms coherent integration (the secondary code is assumed acquired).
- The DLL uses a Dot-Product discriminator, has a 1-Hz loop bandwidth and is based on a 100-ms coherent integration (the secondary code is assumed acquired). The DLL is velocity-aided by the PLL.
- Correlator outputs are provided every 4 ms.

#### Data Demodulation

This program is split into 4 sub-programs:

- Generate a navigation message (with a data stream that is random) of a given length according to the Galileo OS ICD (convolutional coding, interleaving)
- Take into account the correlator output from the receiver behavioral simulator to represent the estimated Galileo E1 OS symbols (soft values).
- Demodulate/decode of a message according to [EC, 2010] based on a soft Viterbi decoder.
- Output statistics in terms of SER, BER, WER and Ephemeris Error Rate (EER)

In this program, a Galileo E1 OS word is assumed to be correct when the CRC is passed. This means that a word is spread across 2 sub-pages of the Galileo E1 message (but is less than 2 sub-pages). Consequently, there is 1 word per 2 sub-pages, or equivalently, per 2 seconds.

#### Simulation Environment

Regarding the simulation scenario, several parameters were tested:

- A TCXO clock that creates a tracking error standard deviation equivalent to the effect of the satellite clock phase noise and the receiver clock phase noise

(also due to the vibration), which is to say around 0.11 radians in accordance with previous values.

- A range dynamics represented in Figure 4 corresponding to the same dynamics used for the tests realized in [RTCA, 2004] and [Tran and Hegarty, 2003]. This does not correspond to a constant jerk over the whole simulation, but an oscillation between extreme values of the worst-case normal maneuver jerk (0.25 g/s). This scenario allows avoiding extreme values of acceleration and velocity that are not realistic and create problems during the simulation (in particular regarding the variation of the phase during the integration interval).

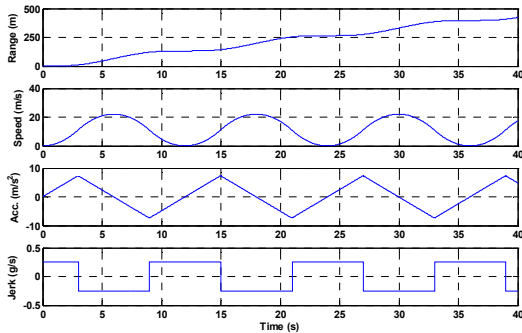

**Figure 4 - Simulated Dynamics for the Demodulation and Cycle Slip Test**

Two different simulation scenarios were tested:

- Configuration 1: static user, no phase noise
- Configuration 2: dynamic user, TCXO phase noise

Note that no multipath were simulated.

The output of the receiver simulator is a stream of data representing the in-phase prompt (raw value) correlator output which is necessary for data demodulation (every 4 ms). It is assumed that although the tracking is done on the pilot channel, the associated correlator outputs of the in-phase prompt channel are representative of the correlator outputs of the in-phase prompt channel of the data component (the correlation losses between the data and pilot channels differ only by 0.1 dB), since the carrier wipe-off on the data channel is directly linked to the carrier tracking on the pilot channel.

Since the goal of the simulations is to find the post-correlation  $C/N_0$  so that the WER equals  $10^{-3}$ , it is necessary to run simulations over a range of at least  $10^4$  words, or 20 000 seconds. In order to make sure that the simulations are run with the correct statistics, the simulations are actually run over periods of 100 000 seconds.

The overall tool was validated by comparing results obtained with GPS L5 in [RTCA, 2004] in terms of SER and BER since GPS L5 uses the same convolutional code as Galileo E1 OS.

### Results

The results of the simulations are shown in Figure 5. The x-axis represents the total post-correlation  $C/N_0$  (data +

pilot). It can be seen that the BER and WER values are significantly below ( $\sim 1$  to 1.5 dB in terms of equivalent  $C/N_0$ ) the theoretical results shown in Figure 3. A similar phenomenon was also observed for similar analysis realized for GPS L5 [RTCA, 2004] and WAAS [RTCA, 2008; Hegarty, 1999] signals. This is very likely due to the fact that the BER computation only represents an upper bound (although supposed to be tight). It is also believed that the asymptotical behavior for low  $C/N_0$  might not be very represented by Eq. 10.

According to Figure 5, the data demodulation threshold is around 28.5 dB-Hz instead of around 30 dB-Hz for the theoretical analysis. Still, in order to take into account phenomenon that might not have been well modeled during the simulations (multipath, AGC, oscillator vibration, etc...), it seems safe to take a data demodulation threshold equal to 29.5 dB-Hz.

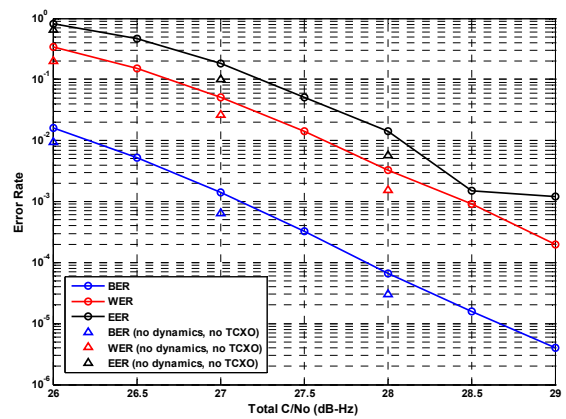

**Figure 5 - Bit Error Rate, Word Error Rate and Ephemeris Error Rate Obtained from Simulations for Galileo E1 OS**

Figure 5 also shows that the impact of the dynamics and the TCXO on the BER and WER is quite low.

### Description of the Considered Scenario and Associated Link Budget

As for the acquisition, the previous data demodulation threshold has to be compared to the link budget of a realistic scenario. It was decided, as in the acquisition section, to use a scenario provided by [RTCA, 2008]: the high altitude/en-route scenario.

#### En-Route Scenario

This scenario is the same as the one taken for the acquisition case. The aircraft will be assumed en-route, over the QZSS hot spot (where the inter- and intra-GNSS interference is the highest), enduring the maximum normal manoeuvre dynamics of 0.25 g/s. In this scenario, the considered satellite is chosen to have an elevation of  $5^\circ$ .

#### Interference Environment

The interference environment is different from the acquisition case:



- the intra-GNSS interference is computed slightly differently (for tracking, the critical factor is the presence of a "critical" satellite, necessary to meet the accuracy and availability requirements, while for acquisition, the critical factor is the ability to acquire at least 5 satellites. ).
- Non-aeronautical Portable Electronic Device aggregate power includes terrestrial emissions,

As for the acquisition case, the equivalent  $N_0$  generated by the inter- and intra-system interference was here approximated (and probably upper-bounded) to -199 dBW/Hz. As a result, the post-correlation equivalent  $N_0$  is chosen equal to -195.9 dBW/Hz.

### Data Demodulation Link Budget

Based on the interference environment defined earlier, it is possible to compute a link budget associated with data demodulation. This link budget is represented in Table 6. It can be seen that the link budget is represented for a satellite at the minimum usable elevation angle. Two cases were taken for the minimum elevation angle: 5° and 10°. It can be seen that due to the minimum antenna gain pattern shape, these two choices lead to differences of the minimum received  $C/N_{0,EFF}$  of 1.5 dB.

Based on this link budget, it can be seen that a data demodulation threshold of 29.5 dB-Hz is acceptable.

**Table 6 - Galileo E1 OS Data Demodulation Link Budget for Worst Case Scenario**

| Line Nb | Parameter (Units)   | SV at 5° | SV at 10° |
|---------|---|----------|-----------|
| 1       | Max Surface Satellite Signal Power at 5° (dBW)  | -157.25  | -157.25   |
| 2       | Antenna Gain (dB)   | -5.5     | -4        |
| 3       | Implementation Loss (dB) <ul style="list-style-type: none"> <li>• AGC+quantization = 1.6 dB;</li> <li>• Correlation loss (BOC(1,1) in 4 MHz) = 1.1 dB.</li> </ul> | -2.7     | -2.7      |
| 4       | C = Recovered SV Carrier Power (dBW) ((1)+(2)-(3))  | -165.45  | -163.95   |
| 5       | $N_{0,EFF}$ (dBW/Hz)  | -195.9   | -195.9    |
| 6       | Min. $C/N_{0,EFF}$ (dB-Hz) ((4)-(5))  | 30.45    | 31.95     |

## GALILEO E1 OS TRACKING THRESHOLD

### Civil Aviation Operational Requirements

The requirements associated with tracking in the current version of the Galileo E1 OS MOPS are:

*"The receiver's pseudorange measurement error shall be no more than 5m (RMS) under interference conditions as described in appendix B, dynamic conditions as defined in*

*section 5.2.13, and the received signal levels and noise as defined in 5.2.4 above."*

It is quite clear that the requirement in terms of pseudorange accuracy should not be a problem for tracking. This will thus not be investigated.

Although not directly specified in the Galileo OS MOPS, [RTCA, 2004; RTCA, 2008] also look at the cycle slip occurrence rate as a requirement. This can indeed be linked to a requirement in terms of continuity.

In general, the value used by RTCA for acceptable cycle slip occurrence rate is  $10^{-5}/s$  and is taken from a requirement for tracking the WAAS signals. This value has been used when assessing the GPS L5 signal in [RTCA, 2004] and could be a good indicator of tracking quality. This value will thus also be taken herein for comparison purpose.

### Theoretical Investigation of the Cycle Slip Occurrence Rate

The probability to have a cycle slip within one second can be modeled for a 1<sup>st</sup> order PLL using [Hegarty, 1999]:

$$P = 1 - e^{-\bar{P}}$$

with

$$\bar{P} = \frac{\pi}{2B_{z,F}} \tanh\left(\frac{\pi T}{\sigma_{\epsilon}^2}\right) \left[ J_0^2\left(\frac{1}{\sigma_{\epsilon}^2}\right) + 2 \sum_{n=1}^{+\infty} (-1)^n \frac{J_n^2\left(\frac{1}{\sigma_{\epsilon}^2}\right)}{1 + \left(\frac{n\sigma_{\epsilon}^2}{T}\right)^2} \right]$$

where

- $\sigma_{\epsilon}^2 = \sigma_{\epsilon,Th}^2 + \sigma_{\epsilon,Obs}^2$ , and

- $J_i$  is the n-th order modified Bessel function of the 1<sup>st</sup> kind

For a 3<sup>rd</sup> order PLL, the rule of thumb is to use the previous formula adding an equivalent 2dB to the actual tested  $C/N_0$ . The results are shown in Figure 6. It can be seen that the target of  $10^{-5}$  cycle slip per second is reached for a total (data+pilot) post-correlation  $C/N_0$  around 25.5 dB-Hz.

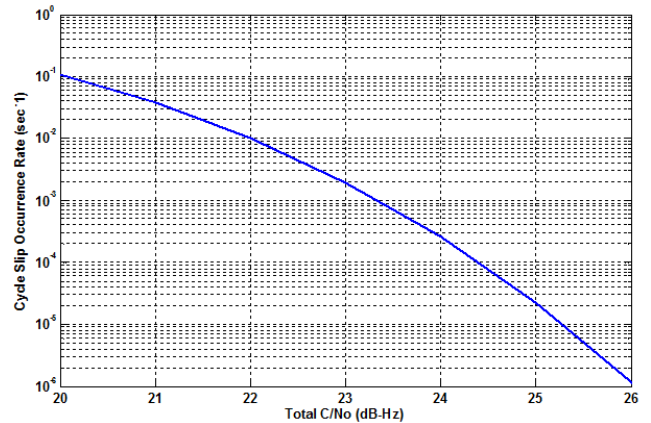

**Figure 6 - Cycle Slip Occurrence Rate Using a BOC(1,1) Receiver with a 4-MHz (Double-Sided) Front-End Filter**

## Investigation of the Cycle Slip Occurrence Rate Through Simulation

Based on the data demodulation simulations, the proposed data demodulation threshold was 29.5 dB-Hz (post-correlation). It is quite clear that at this post-correlation  $C/N_0$ , the cycle slip occurrence rate will be significantly lower than  $10^{-5}$  slip/sec, as shown in Figure 6. This was confirmed through simulations, since based on the same simulation parameters as for the data demodulation analysis, for post-correlation  $C/N_0$  values above 27 dB-Hz, the cycle slip occurrence rate was below  $10^{-5}$  slip/sec (no cycle slip in several 100000-second runs).

As a consequence of the data demodulation and cycle slip occurrence rate analysis, the proposed tracking threshold is the same as for the data demodulation: 29.5 dB-Hz.

## Description of the Considered Scenario and Associated Link Budget

To compare the tracking threshold to a realistic scenario, the same scenario as for the data demodulation case is taken here. This results in the same link budget as for the data demodulation case. As a consequence, it appears that the proposed tracking threshold is acceptable.

## CONCLUSIONS AND FUTURE WORK

This paper has applied and adapted a methodology developed by RTCA to compute the acquisition, tracking and data demodulation thresholds for civil aviation. These thresholds were compared against worst case operational scenarios, and it was shown that they allowed acceptable safety margins.

### Acquisition

Considering that 200 available complex correlators is an acceptable value, it was concluded that:

- if the "on-the-ground" scenario is considered as part of the Galileo "initial acquisition with initialization" requirement, then an acquisition threshold of 34 dB-Hz can be proposed.
- if the "on-the-ground" scenario is not considered as part of the Galileo "initial acquisition with initialization" requirement, then either
  - a lower acquisition threshold, 32 dB-Hz, can be proposed, thus providing a higher safety margin, although it does not appear critical, or
  - the same threshold, 34 dB-Hz, can be kept, but associated with approximately 100 complex correlators.

Regarding the final choice of the acquisition threshold value, there are several points that have to be discussed:

- the acceptance of the assumptions used,
- the acceptable maximum number of complex correlators
- the use of the "on-the-ground" case, although it does not match with the selected operational scenario
- the desired safety margin.

- the partitioning of the allocated acquisition time between the acquisition and verification phases,
- the value of the inter- and intra-GNSS interference in the worst-case link budget, which might have been strongly over-estimated.

## Tracking and Data Demodulation

From the simulations, it seems recommended to propose a data demodulation threshold around 29.5 dB-Hz in order to take into account the effect of potentially un-modeled errors. With this value, there is still a margin of about 1 dB considering a satellite with an elevation of  $5^\circ$  and 2.5 dB for a satellite with an elevation of  $10^\circ$ .

Let us keep in mind that to completely agree with this conclusion, it is necessary to:

- refine the intra-system interference level in the link budget, and
- agree on the definition of a Galileo Word.

## BIBLIOGRAPHY

- [Bastide et al, 2002] Bastide, F., O. Julien, C. Macabiau, B. Roturier (2002), Analysis of L5/E5 Acquisition, Tracking and Data Demodulation Thresholds, Proceedings of the Institute of Navigation GPS (Portland, OR, USA, Sept. 24-27), pp. 2196-2207.
- [EC, 2010] European Commission (2010), European GNSS (Galileo) Open Service – Signal-In-Space Interface Control Document Issue 1, February.
- [Hegarty, 1997] Hegarty, C. (1997), Analytical Derivation of the Maximum Tolerable In-Band Interference Levels for Aviation Applications of GNSS, Navigation: Journal of the Institute of Navigation, Vol. 44, No. 1, Spring 1997, pp. 25-34.
- [Hegarty, 1999] Hegarty, C. (1999), Evaluation of the Proposed Signal Structure for the New Civil GPS Signal at 1176.45 MHz, WN99W0000034, The MITRE Corporation
- [Irsigler and Eissfeller, 2002] Irsigler, M., and B. Eissfeller (2002), PLL Tracking Performance in Presence of Oscillator Phase Noise, GPS Solutions, Vol. 5, No. 4, pp. 45-54.
- [Julien, 2005] Julien, O. (2005), Design of Galileo L1F Receiver Tracking Loops, Ph.D. thesis, Department of Geomatics Engineering, University of Calgary, UCGE Report 20227.
- [Julien, 2010] Julien, O., C. Macabiau, J-L Issler, and L. Ries (2010), Galileo E1 OS/SoL Acquisition, Tracking and Data Demodulation Performances for Civil Aviation', Proceedings of NaviTec 2010 (Noordwijk, The Netherlands, 8-10 Dec.).
- [RTCA, 2004] RTCA SC-159 (2004), Assessment of Radio Frequency Interference Relevant to the GNSS L5/E5a Frequency Band, RTCA DO 292, July 2004.
- [RTCA, 2006] RTCA, SC-159 (2006), Minimum Operational Performance Standards for Global Positioning System/Wide Area Augmentation System Airborne Equipment, RTCA DO 229D, Dec. 13 2006.



- [RTCA, 2008] RTCA SC-159 (2008), Assessment of Radio Frequency Interference Relevant to the GNSS L1 Frequency Band, RTCA DO 235B, March 2008.
- [Stephens and Thomas, 1995] Stephens S.A., and J. B. Thomas (1995), Controlled-Root Formulation for Digital Phase-Locked Loops, in IEEE Transactions on Aerospace and Electronic Systems, Vol. 31, No. 1, pp. 78-95.
- [Tran and Hegarty, 2003] Tran, M., and C. Hegarty (2003), Performance Evaluation of the New GPS L5 and L2 Civil (L2C) Signals, Proceedings of the ION NTM 2003 (Anaheim, CA, USA, Jan 22-24).
- [Wallner et al, 2006] Wallner, S., J.-A. Avila-Rodriguez, G.W. Hein, and J. J. Rushanan (2006), Galileo E1 OS and GPS L1C Pseudo Random Codes - Requirements, Generation, Optimization and Comparison, Proceedings of the ION GNSS Conference (Fort Worth, USA, Sept. 25-28).